

Compact Pellet

Instruction Manual

English

Models

Compacta Eco 12 Compact
Compacta Eco 18 Compact
Compacta Eco 24 Compact

Be sure to read these instructions carefully before installing, using and servicing the unit. The product is supplied with this instruction manual.

Thank you for purchasing a SOLZAIMA equipment.

Please read this Manual carefully and keep it for future reference.

* All products meet the requirements of the Construction Products Regulation (Reg. UE n°305/2011), being approved with the CE mark of conformity;

* The compact pellet are built to EN 14785:2008 standards;

* SOLZAIMA accepts no responsibility for any damage to the equipment when it is installed by unqualified personnel;

* SOLZAIMA accepts no liability for any damage to the equipment when the rules for installation and use set out in this Manual are not followed;

* All local regulations, including the so-called national and European standards, must be respected when installing, operating and maintaining the equipment;

* Whenever you need assistance you should contact the supplier or installer of your equipment. You must provide the serial number of your Compact which can be found on the identification plate on the back of the equipment and on the label attached to the plastic cover of this manual;

* Technical assistance should be carried out by your installer or solution provider, except in special cases after assessment by the installer or technician in charge of assistance, who will contact SOLZAIMA if deemed necessary;

* If you need more information about the electronics applied in the SOLZAIMA equipment you can read the following QR Codes.



[Columbus Electronics](#)



[Not applicable Columbus Electronics](#)



Technical support contacts:

www.solzaima.pt

apoio.cliente@solzaima.pt

Address: Rua da Cova da Areia (E. M. 605), 695;
3750-071 Aguada de Cima
Águeda - Portugal

Índice

1.	Solzaima	1
2.	Package Content	2
2.1.	Unpacking the unit	2
3.	Safety precautions 	3
3.1.	For your safety, we recommend that:	3
4.	Advice in case of a chimney fire (including the equipment)	5
5.	Technical Specifications	6
6.	Compact pellet installation	9
6.1.	Installation requirements	9
6.2.	Installation of ducts and Smoke exhaustion systems	10
6.3.	Installation without chimney	11
6.4.	Chimney installation	14
7.	Hydraulic installation	16
7.1.	Operating mode for radiators/inertia tank	16
8.	Fuel	17
9.	Compact pellet use	18
10.	Remote Control	20
11.	Alarm / Failure / Recommendation List 	37
12.	Columbus Electronics	39
13.	List Alarms / malfunctions / recommendations – Columbus Electronics	62
14.	Operating the unit	65
14.1.	Starting-up the unit	65
14.2.	Stop	65
14.3.	Turning off the unit	65
15.	Instructions for removing the side covers	66
15.1.	Removing the side covers	66
15.2.	Pellet hopper lid	66
15.3.	Replenishing the pellet tank	66
16.	Installation and operation with external control (chronothermostat) – not included in compacts	67
16.1.	Instruction four mounting the external control unit	69
17.	Maintenance 	71
17.1.	Daily Maintenance	71
17.2.	Weekly maintenance	72
17.3.	Additional cleaning	75
18.	Maintenance plan and record	78

19.	Etiqueta guia de manutenção 	82
20.	Installation Schemes	83
21.	Electrical Diagram of the Compact unit	87
21.1.	Electrical Diagram – not applicable to Columbus Electronics	87
21.2.	Electrical Diagram – Applicable to Columbus Electronics	88
22.	Hydraulic Pumps	89
22.1.	Pump UPM3 with Hybrid 15-70 130 mm	89
22.2.	Bomba Wilo 15-130/7-50	91
23.	End of life of a compact pellet	99
24.	Sustainability	99
25.	Glossary	100
26.	Warranty	102
27.	Annexes	111
27.1.	Timer weekly programming (not applicable to Columbus Electronics)	111
27.2.	Flow Chart	112
28.	Declaration of Performance	115

1. Solzaima

Solzaima's vision has always been clean, renewable and more economical energy. For this reason, for over 45 years we have been dedicated to the manufacture of biomass heating equipment and solutions.

As a result of the persistence and unconditional support of its network of partners, Solzaima is today the leader in the production of biomass heating, the best example of which are the water central heating stoves and its range of pellet stoves and compacts.

Every year we equip more than 20,000 homes with biomass heating solutions. A sign that consumers are paying attention to more ecological and more economical solutions.

Solzaima has ISO9001:2015 Quality certification and ISO14001:2015 Environmental certification.

2. Package Content

The equipment is shipped from the Solzaima facility with the following contents:

- Compacta Eco, of power 12 kW, 18 kW or 24 kW;
- Key for steam trap;
- Power cable.

2.1. Unpacking the unit

Para proceder ao desembalamento do equipamento, dever-se-á proceder como exemplificado nas seguintes fotos. Em primeiro lugar, deverá ser retirado o saco retráctil que envolve o equipamento (Figure 1 - Unpacking the compact

-a). Em seguida, deverão ser desapertadas as quatro peças que seguram o equipamento à palete de madeira (Figure 1 - Unpacking the compact -b e c).



a)



b)



c)

Figure 1 - Unpacking the compact

3. Safety precautions

Solzaima will not assume any responsibility if the precautions, warnings and operating standards of the equipment are not respected.

The equipment manufactured by Solzaima is simple to operate and special attention has been given to its components in order to protect the user and the installer against possible accidents.

The installation must be done only by authorized persons, who must deliver to the buyer a declaration of conformity of the installation, and who will be totally responsible for the final installation, and consequently, for the good functioning of the product.

This equipment must be intended for the use for which it was expressly manufactured. All contractual or extra-contractual liability of the manufacturer is excluded if it causes injury to persons, animals or things, due to installation errors, maintenance errors or improper use.

After you have removed the packaging, make sure that the contents are complete and undamaged. If the contents of the packaging do not correspond to those indicated in point 1, contact the dealer from whom you bought the device.

All the components that make up the equipment guarantee its operability and energy efficiency and must be replaced with original parts by an authorized service center.

The maintenance of the equipment must be performed at least once a year, for this you should contact your specialized installer.

This instruction manual is an integral part of the product. Make sure you are always near the device.

3.1. For your safety, we recommend that:

- The compact pellet is a biomass heating unit. Be sure to carefully read and understand the information contained in this book, before handling or operating the unit;
- Make sure the hydraulic circuit is correctly assembled and connected to the water supply system before turning on the compact pellet;
- The compact is not intended for use by children or persons with a physical, sensory or mental handicap, unexperienced or unaware of its proper use, unsupervised or not instructed concerning the use of the unit;

- Do not touch the compact when barefoot or any part of your body is wet or humid;
- Do not tamper with any safety or adjustment features of the unit without the manufacturer's authorisation;
- Do not cover or reduce the size of the aeration vents existing near the installation area;
- The compact pellet needs air circulation for proper combustion, so possible air tightness of the location or any existing air extraction sources in the room may prevent the unit's proper operation;
- The existence of aeration vents is a requisite for proper combustion;
- Do not leave the packing materials near children;
- During the unit's normal operation do not attempt to open the compact's door;
- Avoid direct contact with parts of the unit that overheat during operation;
- Check the fume duct for blockages before turning on the unit after a long period of inactivity;
- This compact pellet is intended for residential use in a protected environment. The unit might get turned off by any safety systems installed in the household. If this occurs, contact the technical assistance. Under no circumstances should you disarm the safety systems;
- The compact pellet is a biomass heating unit equipped with a fume exhaustion system powered by an electric exhauster. The occurrence of any power failure during its use may prevent the fume exhaustion thus causing the room to be filled with smoke. For this reason, you should have a natural fume exhaustion system, like a chimney, installed;
- REDPOD offers you an optional safety system which allows the compact unit to be connected to a UPS to allow that during any power failure the fume exhaustion system will still operate until complete exhaustion of all compact fumes;
- If you intend to use the compact unit unsupervised or while you are away from home, you should use the above safety system for total safety during any power failure;
- During operation, NEVER turn off the compact pellet by unplugging the power cord from the wall socket. The fume exhaustion system on the compact pellet is power-operated so disconnecting the power plug will prevent the exhaustion of combustion fumes;

- Before performing any maintenance or assistance to your unit, disconnect it from the power mains. Before performing any of these operations, allow the unit to cool down completely (if previously operating);
- Never touch the interior of the compact when connected to the power mains;
- • For this compact, the maximum setting for the water temperature that can be specified by the user (water set-point temperature) is 80°C. If a temperature of 90°C is reached, the compact automatically turns off causing the corresponding alarm to go off.

4. Advice in case of a chimney fire (including the equipment)

- Put the fire out without endangering your life;
- If you cannot put out the fire within one minute, call the fire department;
- Close the doors and windows of the room where the fire occurred;
- Turn off the electricity and gas before you leave home;
- Once outside your home, provide information that will help put out the fire, such as: location of the fire and materials that are burning.

5. Technical Specifications

Features	SZM Eco C 12	SZM Eco C 18	SZM Eco C 24	Un
Weight	1210	1301	1301	mm
Height	620	666	666	mm
Depth	700	740	740	mm
Fume discharge pipe diameter	100	100	100	mm
Reservoir capacity	42	72	72	kg
Maximum heating capacity	295	409	534	m ³
Maximum overall thermal power (air/hydro)	11,5	16,6	22,2	kW
Minimum thermal power (air/hydro)	3,8	5,1	6,7	kW
Minimum fuel consumption	1,1	1,4	1,7	kg/h
Maximum fuel consumption	3,0	4,2	5,4	kg/h
Rated electrical current	43	86	86	W
Electric power at start-up (<10 min.)	406	434	434	W
Rated voltage	230	230	230	V
Rated frequency	50	50	50	Hz
Thermal yield at rated thermal power	92	91,5	91	%
Thermal yield at reduced thermal power	95	95	95	%
Combustion gas flow (máx)	44	56,4	70	g/s
Combustion gas flow (min)	21	27	34	g/s
Max. Gas temperature	108	119	131	°C
CO emissions at nominal thermal power	0,0136	0,0159	0,0184	%
CO emissions at reduced thermal power	0,0256	0,0300	0,0343	%
Draught in the chimney	12	12	12	Pa
Compact's water volume	19	22	22	L
Fume extractor noise emission	49,1	49,1	49,1	dB(A)

Table 1 - Technical specifications

The tests were performed using wood pellets with a heating capacity of 4.9 kWh/kg. The above information was obtained during product homologation tests performed by independent laboratories accredited for pellet unit tests.

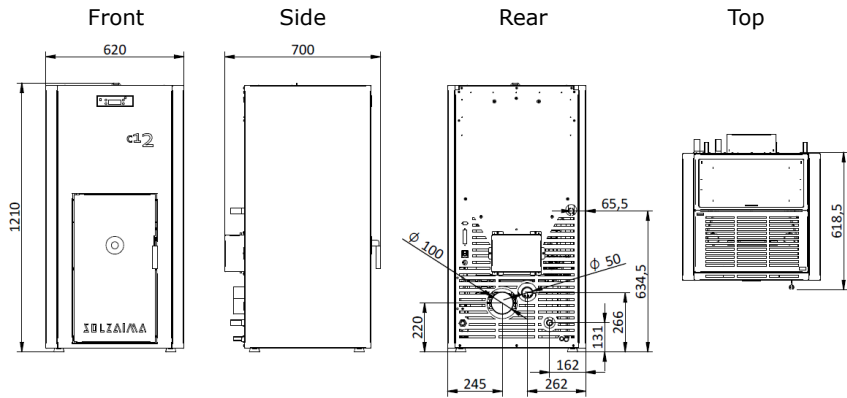

Figure 2 – Compact pellet Compacta Eco 12 dimensions

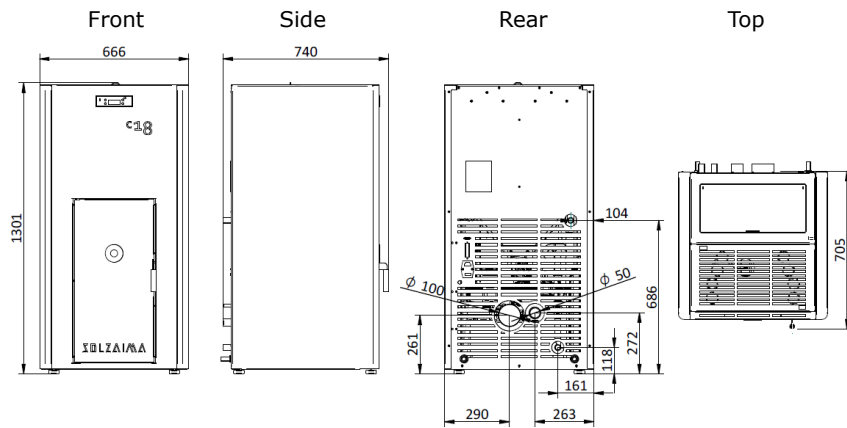

Figure 3 – Compact pellet Compacta Eco 18 dimensions

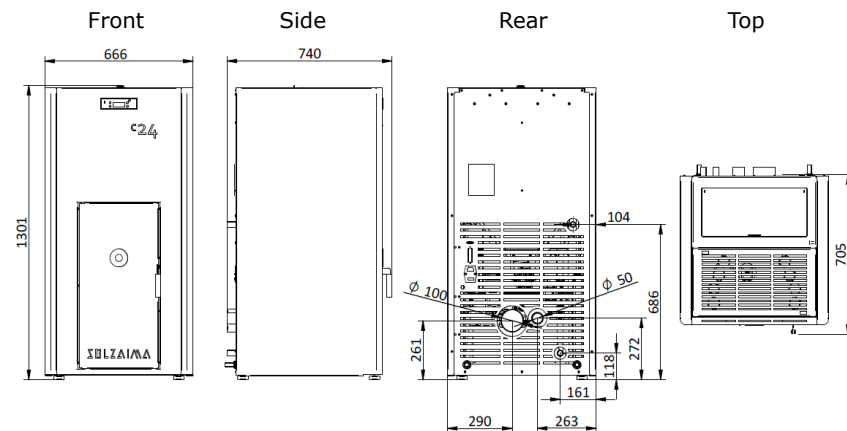

Figure 4 – Compact pellet Compacta Eco 24 dimensions

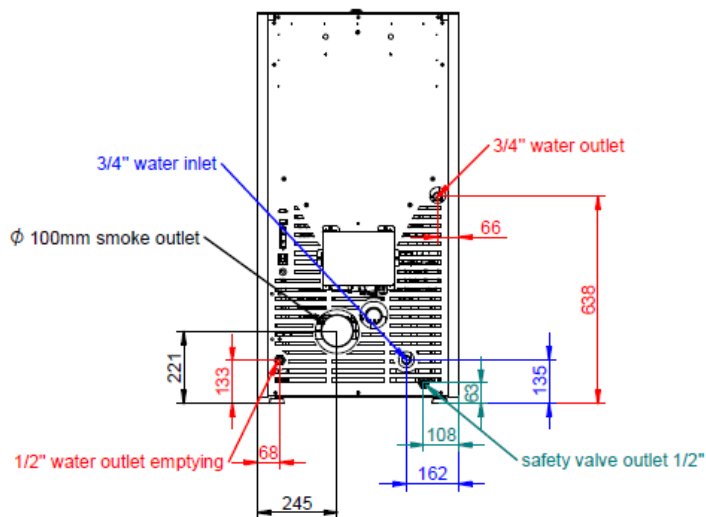

Figure 5 - Hydraulic connections for the Compacta Eco 12 compact

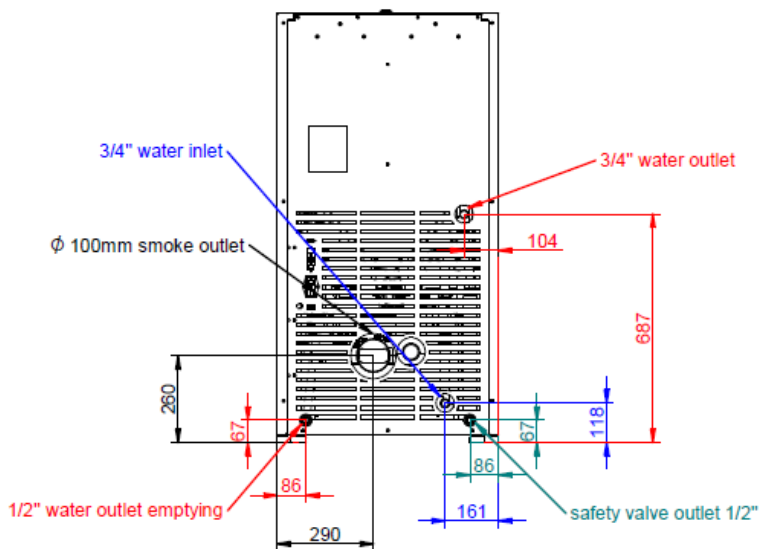

Figure 6 - Hydraulic connections for the Compacta Eco 18 and 24 compacts

6. Compact pellet installation

Before starting the installation, perform the following actions:

- Check immediately upon receipt that the delivered product is complete and in good condition. Any defects must be reported before installing the appliance.
- The compact has four height-adjustable feet at its base, allowing a simple adjustment on uneven floors.



Figure 7 - Adjustable Feet

- Connect a 100 mm diameter pipe in compacts between the flue gas outlet and a flue for exhausting fumes to the outside of the building (e.g. chimney) - check diagrams in Section 6.3.
- If a pipe is used for combustion air intake from outside, it must not be longer than 60 cm horizontally or contain disturbances (e.g. bends).
- Carry out hydraulic installation (see point 20).
- Connect the 230VAC supply cable to an earthed electrical socket.
- The machine is equipped with a chrono-thermostat on the control panel. As an option, a conventional external programmer (not included) can be used to automatically set the device's operating periods.

6.1. Installation requirements

The minimum distances of the pellet stove from particularly flammable surfaces are shown in Figure 8.

On top of the pellet stove, a minimum distance of 100 cm from the ceiling of the room must be maintained, especially if the ceiling contains flammable material. The base of the compact must not be made of combustible material, (e.g. carpeting), so there must always be adequate protection.

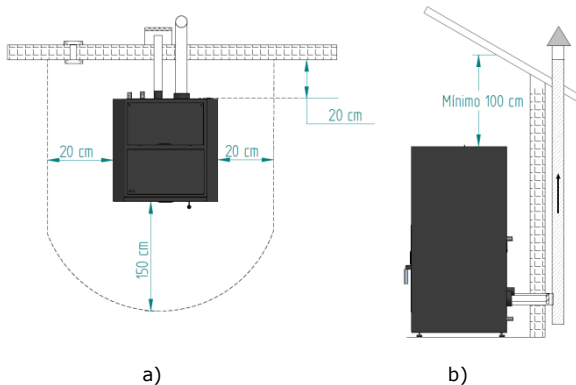

Figure 8 - Minimum distances from all surfaces: a) top view of the equipment installation; b) side view of the equipment installation



WARNING!

Keep combustible and flammable materials at a safe distance.

6.2. Installation of ducts and Smoke exhaustion systems

- The construction of the gas exhaust pipe must be suitable for the purpose according to the requirements of the site and in compliance with the regulations in force.
- Important! A T-inspection with a tight-fitting lid must be inserted at the outlet of the compact pellet exhaust pipe to allow for regular inspection or discharge of heavy dust and condensate.
- As shown in Figure 8, the exhaust ducting should be made so that cleaning and maintenance are ensured by inserting the inspection points.
- Under nominal operating conditions, the flue gas draft must give rise to a depression of 12 Pa, measured 1 meter above the chimney neck.
- The compact must not share the chimney with other equipment.
- The pipes outside the place of use must be double-insulated stainless steel, with an internal diameter of 100 mm.
- **The smoke exhaust pipe, can generate condensation, in this case it is advisable to establish adequate condensate collection systems.**

6.3. Installation without chimney

The installation of the pellet stove when there is no chimney must take place, as in Figure 9, by bringing the smoke exhaust pipe (with a minimum internal diameter of 80 mm for the air version and 100 mm for the water version) directly outside and above the roof.

Properly anchored double-walled insulated stainless steel pipes should be used to prevent condensation phenomena.

Provide at the base of the pipe a T for periodic inspections and annual maintenance, as exemplified in Figure 9.

In Figure 10, the basic requirements for the installation of the compact chimney are represented.

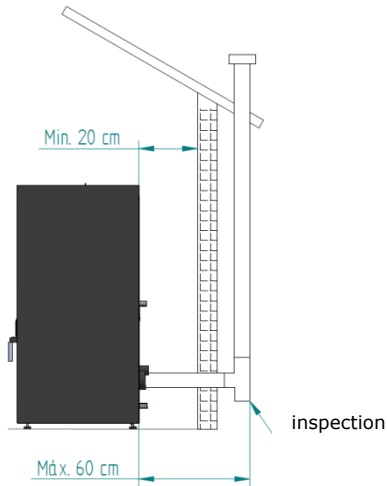
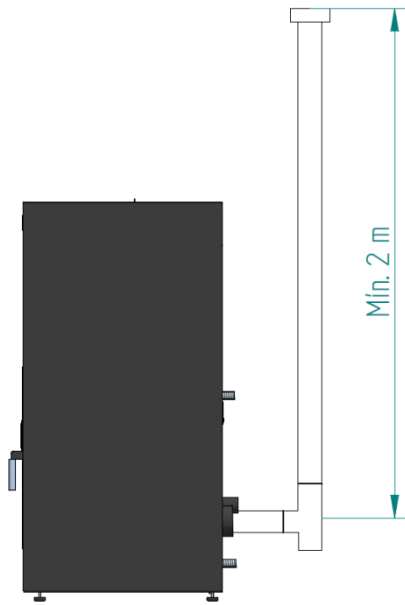
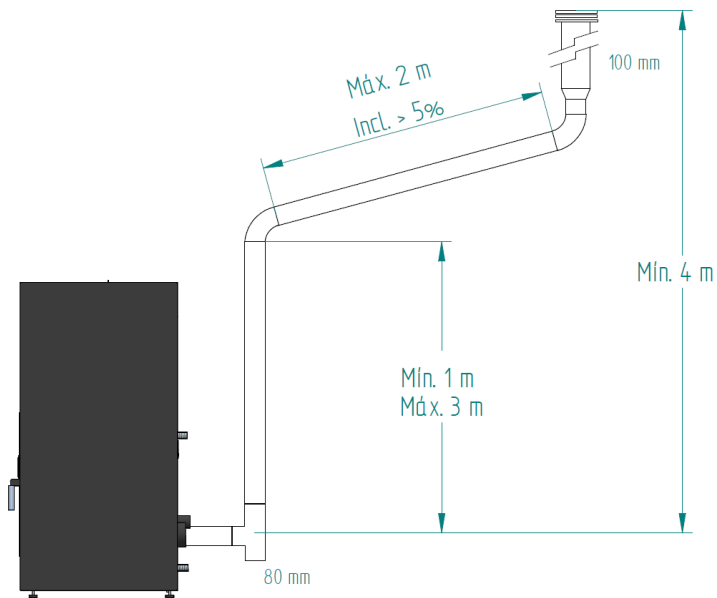

Figure 9 - Side view of the installation without chimney, with example of the inspection point



a)



b)

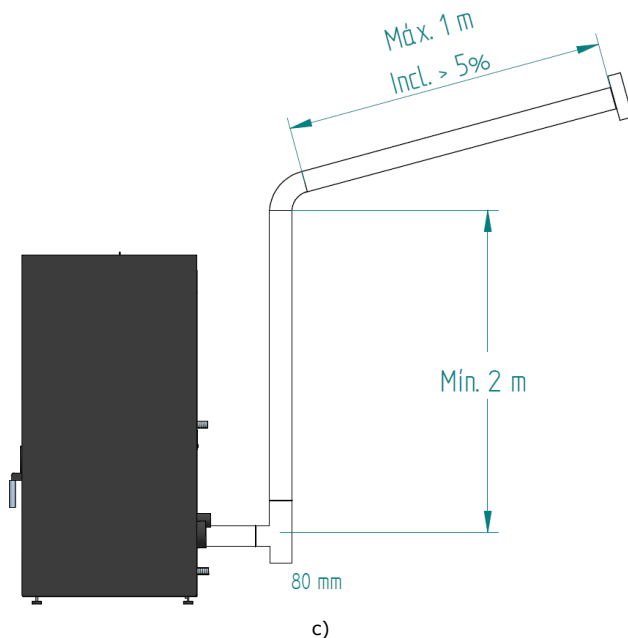

Figure 10 - Examples of type installations

! Failure to comply with these requirements will jeopardize the correct operation of the compact. Comply fully with the indications on the diagrams.

! The compacts operate with the combustion chamber in a depression, so it is absolutely necessary to have a smoke evacuation duct that extracts the combustion gases properly.

Smoke duct material: The pipes to be installed must be rigid, of stainless steel with a minimum thickness of 0.5 mm, with joints for joining the different sections and fittings.

Insulation: Smoke ducts must be double walled with insulation to ensure that the smoke does not cool down during its journey to the outside, which would cause inadequate draft and condensation that can damage the appliance.

Output "T": Always use a "T" with registration at the compact outlet.

Antivento Terminal: An anti-vent terminal should always be installed to prevent the return of fumes.

Chimney Depression: The figures illustrate three type layouts, with the appropriate lengths and diameters. Any other type of installation must ensure that a depression of 12 Pa (0.12 mbar) measured hot and at maximum power is generated.

Ventilation: For the compact to work properly, **the place where the appliance is installed must have an air inlet with a minimum section of 100 cm², preferably near the back of the compact. The compact has a round tube (50 mm) that can be connected to the outside of the house.**

If there is an air extraction system in the home (kitchen extractor), it is necessary to have a ventilation section that is larger and better sized than the various pieces of equipment that extract air from the home.

Placing the compact in places where kitchen extractors or gas extractors are installed may affect the proper operation of the compact. It is recommended that the compact is switched off when these extractors are in operation.

6.4. Chimney installation

As shown in Figure 11, the compact pellet installation brings the 100 mm diameter flue pipe directly to the chimney. If the chimney is too large, it is recommended to pipe the flue outlet with a minimum internal diameter pipe of 100 mm.

Provide at the base of the pipe a "T" for periodic inspections and annual maintenance, as illustrated in Figure 11.

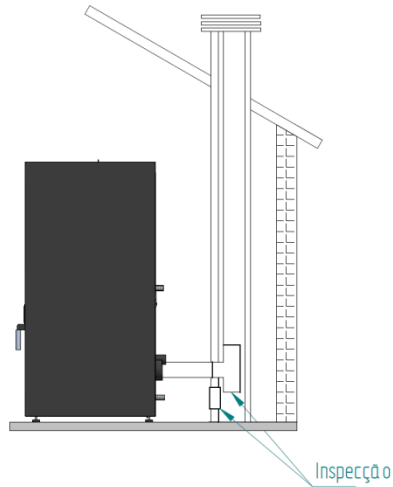

Figure 11- Side view of the chimney installation, with example of the inspection point

When atmospheric conditions are so adverse as to cause strong disturbance to the compact's fumes draft (in particular very strong winds), it is advisable not to use the compact.

If the equipment is not used for a long period of time, the user must ensure that there is no blockage in the chimney pipes before lighting.

7. Hydraulic installation

* The possible connection diagrams for a central heating system, with or without domestic water heating, can be found in section **Error! Reference source not found.** (installation diagrams);

* The compact pellet comes with a circulating pump, an expansion vessel with a volume of 6 liters (Compacta Eco 12 model) or 10 liters (Compacta Eco 18 and 24 model and precharge of 1 bar) and a 3 bar safety valve;

* Working pressure is between 1 and 1.5 bar;

* For emptying the device, a "T" with a tap must be placed at the outlet (with connection to the sewer); the outlet of the safety valve (3 bar) must also be connected to the sewer;

* The heat carrier fluid must be water with the addition of an anti-corrosion product, non-toxic and in the quantity recommended by the manufacturer; if there is a risk of freezing in the space where the compact pellet is located or in the fluid conduits, the installer must add to the circulating fluid an anti-freeze in the proportion recommended by the respective manufacturer, to prevent freezing at the absolute minimum temperature expected.

7.1. Operating mode for radiators/inertia tank



IMPORTANT! The compact is programmed to work directly for radiators, in case you want to install the compact with an inertia or DHW tank, we recommend changing the "OFF" temperature of the circulating pump, placing the same temperature of the tank or 1°C above that temperature, you must deactivate in the "HYDRO Menu" the "Modulating Pump" and the "hydro independent" modes and switch in the display from "Auto" to "Manual" mode and select power 5 (Fire 5).

It is necessary to change the smoke temperatures ("Toff" and "Ton") in the "Activation" menu. For these changes it is necessary to access the "Technical Menu" on the display, please request password from the factory.

8. Fuel

The only fuel that must be used to operate the compact is pellet. No other fuel may be used.

Use only pellets certified to EN 14961-2 grade A1 with a **diameter of 6 mm** and a length that can range from **10 to 30 mm**.

The maximum permitted moisture content of the pellets is 8% of their weight. To ensure good combustion, the pellets must maintain these characteristics, so it is recommended to keep them in a dry environment.

The use of different pellets decreases the efficiency of the compact pellet and causes poor combustion processes.

As a recommendation, always opt for certified pellets, not forgetting that before buying large quantities you should always test a sample.

The physicochemical properties of pellets (namely the gauge, friction, density and chemical composition) can vary within certain tolerances and according to each manufacturer. This fact can cause changes in the feeding process and consequently different dosages (with more or fewer pellets).

The compact allows the adjustment of the pellet dose in the start-up phase and in the power steps by $\pm 25\%$.

 **WARNING!**

The device may NOT be used as an incinerator.

9. Compact pellet use

! The pellet stove must be serviced as described in point 3.6, page 99 (Warranty). In order to adjust the operating parameters of the stove (pellet appliances), the dosing must be adjusted as described in section 8 of this manual. The pellet dose must be adjusted according to the gas temperature and pellet consumption of the appliance at the rated power described in Table 1, page 6, to ensure that the appliance delivers the correct power.

Recommendations

Before you start the appliance you must check the following points:

- Ensure that the compact is correctly connected to the mains via the 230VAC supply cable.



Figure 12 - Power connection plug

- Check that the pellet tank is filled. There is a safety grille inside the pellet tank to prevent the user from accessing the worm screw.
- Ensure that before each ignition the burner is unobstructed.

! **The compact's combustion chamber and door are constructed of iron plate painted with high temperature paint, releasing fumes in the first few firings due to the curing of the paint. If this occurs, open the windows and doors leading to the outside to ventilate the room. Avoid touching the door of the equipment during the first firing, so as not to leave permanent marks on the paint. The paint dries at approximately 300°C for 30 minutes.**

Make sure the hydraulic circuit is correctly mounted and connected to water.

It must be verified that there is sufficient air circulation in the room where the installation is made, otherwise the equipment will not work properly. For this reason you should pay attention to whether there are other heating equipment that consume air for their operation (eg, gas equipment, diesel compacts, etc.), and it is not advisable to operate such equipment at the same time.

The compact pellets have a probe to measure the ambient temperature. This probe is fixed to the grid at the back (Figure 13). For a more accurate ambient temperature reading, avoid contact of the probe end with the machine structure. If you wish, you can also fix it to the wall next to the machine.



Figure 13 – Ambient Temperature Probe

10. Remote Control

10.1. Remote control and display

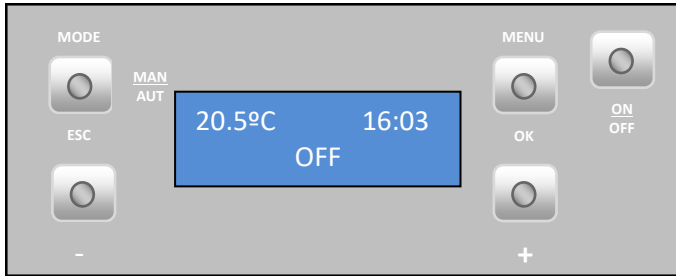

Figure 14 - Remote control and display



a) Key to toggle between manual and automatic mode and exit menus (esc).



b) Key to access menus and confirmation key (ok).



c) Key to start/stop the unit and reset error messages.



d) Key to scroll the menus to the left, to increase and reduce the fan flow and increase or reduce the set-point temperature.



e) Key to scroll menus to the right to increase and reduce the unit's power.

Figure 15 - Control keys

10.2. Display information summary

10.2.1. Menu

Menu showing compact in power "off", the room temperature in °C and Time.

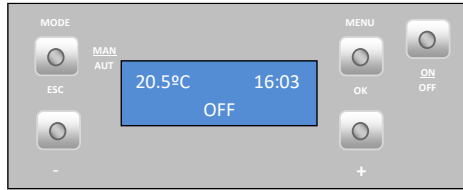

“Auto” mode: in this mode, the unit will be turned on at maximum power until reaching a temperature of 1°C above the selected temperature (set point temperature). Upon reaching the set temperature, the unit toggles to the minimum operating power.

The set-point temperature can be set between 5 and 35°C by pressing the "-" key. The "+" key allows the user to set the ventilation speed between 1-5 or to automatic mode

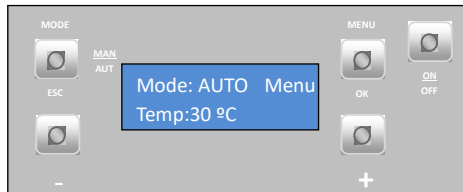

10.2.2. Water temperature

Press the Menu key twice to set the water temperature; the “Temp. Agua” (Water temp.) appears on the display. Press Set to display the “T. Aquecimento” (Heating Temperature) menu.

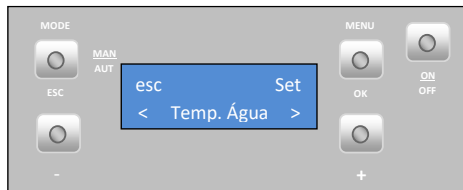

- Heating Temperature

To set the desired **heating temperature** press "set". The display starts to flash. Press the "+" or "-" key to select the desired temperature and then "ok" to confirm. Press the "+" key to go to the "Temperatura de sanitários" (Bathroom Temperature) menu.

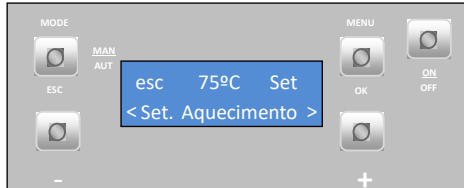

Note: in the water equipment, the water temperature can be regulated by the user (water set-point temperature) between 50 and 80°C.

- Bathroom temperature (**this mode is disabled**)

10.2.3. Date/Time

To set the **date and time**: press the Menu key twice; "Dia e Hora" (Date and Time) appears on the display. Press "set" to see the "Hora" (Time) menu:

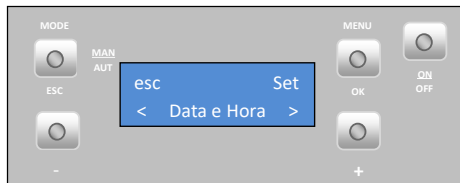

- Time

To set the **time** press "set". The display starts to flash. Press the "+" or "-" key to select the desired time and then "ok" to confirm. Press the "+" key to go to the "Minutos" (Minutes) menu.

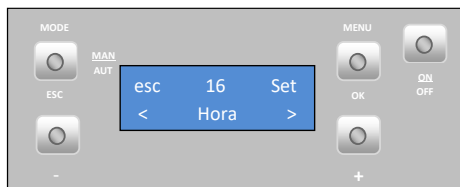

- Minutes

To set the **minutes** press "set". The display starts to flash. Press the "+" or "-" key to select the desired minutes and then "ok" to confirm. Press the "+" key to go to the "Dia" (Day) menu.



- Day

To set the **day of the week** press "set". The display starts to flash. Press the "+" or "-" key to select the desired day and then "ok" to confirm. Press the "+" key to go to the "Dia Num." (Day Number) menu.

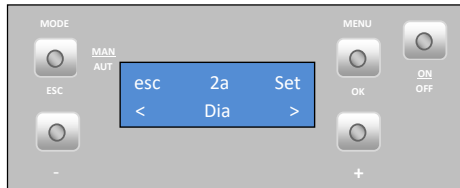

- Day of the month

To set the **day of the month** press "set". The display starts to flash. Press the "+" or "-" key to select the desired day and then "ok" to confirm. Press the "+" key to go to the "Mês" (Month) menu.

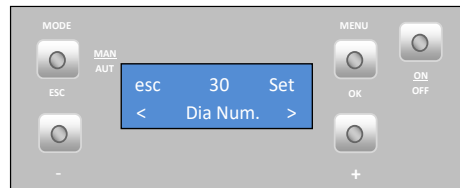

- Month

To set the **month** press "set". The display starts to flash. Press the "+" or "-" key to select the desired month and then "ok" to confirm. Press the "+" key to go to the "Ano" (Year) menu.

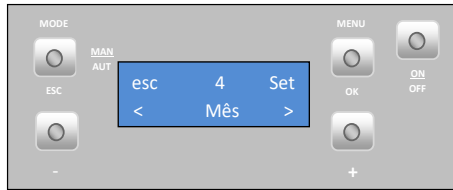

- Year

To set the **year** press "set". The display starts to flash. Press the "+" or "-" key to select the desired year and then "ok" to confirm. Press "esc" to return to the "Dia e Hora" (Date and Time) menu then "+" scroll to the next menu. The Crono (Timer) menu appears.



10.2.4. Timer

The compact is equipped with a timer that allows the unit to be turned on or off at a specific time.

- Activation

To **activate the timer** press "set". The "Habilitação" (Activation) menu appears. The timer may only be activated after the configurations have been set, as shown below.

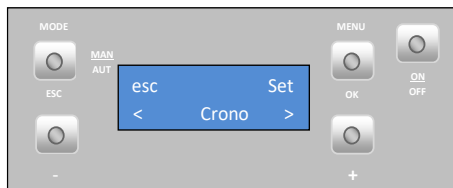

To **activate the timer mode** press "set". The display starts to flash. Press the "+" or "-" key to select "On" or "Off" and then "ok" to confirm. Press the "+" key to go

to the "Reiniciado" (Reset) menu.

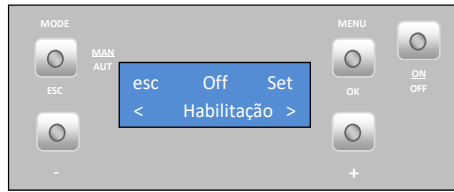

This menu allows you to delete any programme settings. To do this, press "set". The "Confirmar?" (Confirm?) prompt appears. Press "set" again to confirm that you want to delete the settings or "esc" to exit.

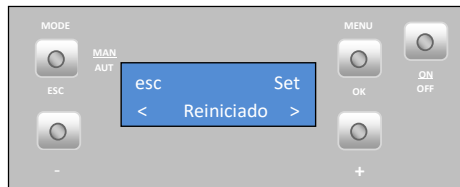

The unit's **programmer** lets you choose from 6 different programmes for each day of the week.

To set up **programmes "P1" to "P6"**, select the desired programme using the "-" and "+" keys, and press "set" to select. The "P1 Habilitação" (Activation) menu appears.

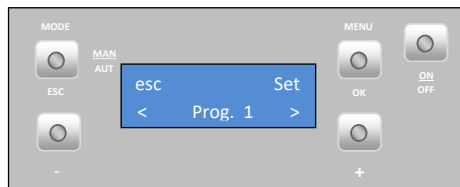

Press "set" again and, when the display starts to flash, press "+" or "-" to select "On" or "Off". Press "ok" to confirm the selection. Press the "+" key to go to the "P1 A. Inicio" (P1 A. Start) menu.

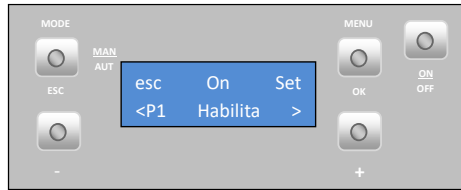

To set the **starting time** for Programme 1, press "set". The display starts to flash. Press the "+" or "-" key to select the desired time and then "ok" to confirm. Press the "+" key to go to the "P1 H. Stop" (P1 Time Stop) menu.

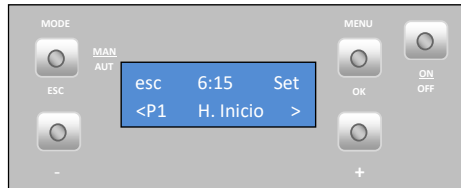

To set the **stopping time** for Programme 1, press "set". The display starts to flash. Press the "+" or "-" key to select the desired time and then "ok" to confirm. Press the "+" key to go to the "P1 Temp. Ar" (P1 Air Temp) menu.

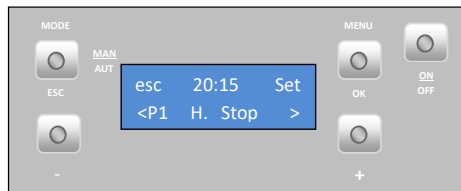

To set the **set point room temperature** for Programme P1, press "set". The display starts to flash. Press the "+" or "-" key to select the desired temperature and then "ok" to confirm. Press the "+" key to go to the "P1 Temp. Água" (P1 Water Temp) menu.

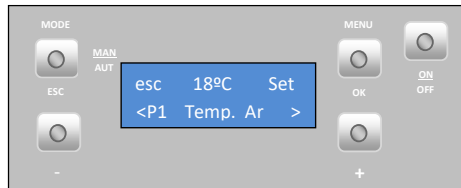

To set the **water set point temperature** (only for the **back compact model**) for Programme P1, press "set". The display starts to flash. Press the "+" or "-" key to

select the desired temperature and then "ok" to confirm. Press the "+" key to go to the "P1 Fire" menu.

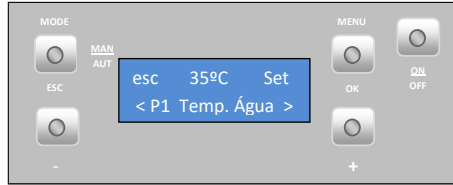

To set the **operating power** (1 to 5) for Programme P1, press "set". The display starts to flash. Press the "+" or "-" key to select the desired power and then "ok" to confirm. Press the "+" key to go to the "P1 Dia" (P1 Day) menu.

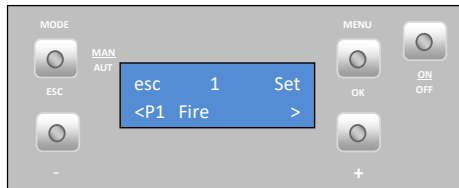

To select the **days of the week** that you want the P1 Programme to run, press "set" and then select the day of the week using the "-" and "+" keys. Press "set". The display starts to flash. Select "On" or "Off" using the "-" and "+" keys. Press "ok" to confirm the selection. Press the "esc" key to go to the "P1 Dia" (P1 Day) menu. Press "esc" twice and then "+" to go to the "ConFigureções" (ConFigureition) menu.

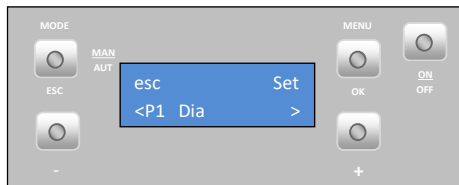

Repeat the above steps for programmes P2 to P6.

Note: After setting up the programmes, please remember to activate them on the "Habilitações" (Activation) menu.

10.2.5. Sleep (this menu only appears with the compact ON)

The "Sleep" menu allows you to setup the time you want the compact to turn off.

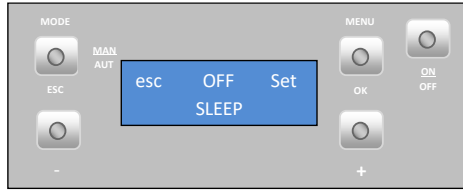

Press "set". The display starts to flash. Select the desired time using the "-" and "+" keys. After choosing the time, press "ok" to confirm. Press "esc" to return to the menu and then "+" to go to the conFIGuretion menu.

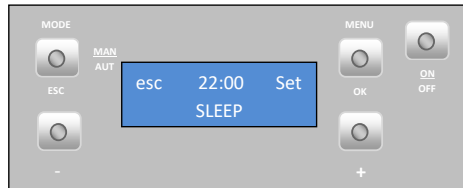

10.2.6. User Info

In this menu the user can view some information about the compact.

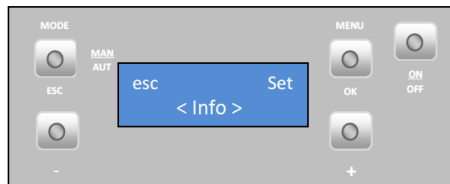

Pressing "set" brings up the "Plug Code" Menu.

Software / firmware code of the motherboard. Pressing the "+" key brings up the next menu "security code".



Security software / firmware code. Pressing the "+" key brings up the next menu "Código Display".

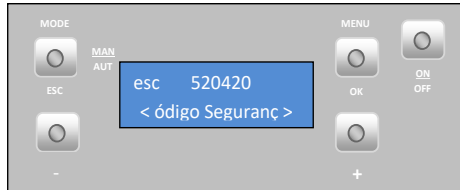

Software code / display firmware. Pressing the "+" key takes you to the next menu "código de parâmetros".

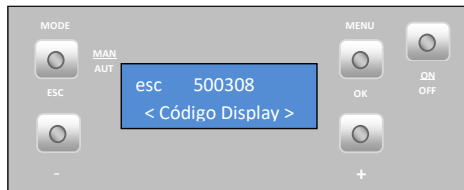

Parameter code. Pressing the "+" key takes you to the next menu.

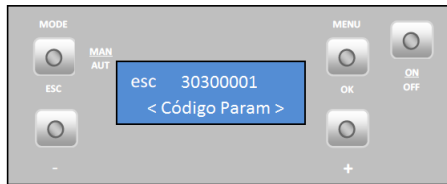

This menu indicates how many working hours the compact has.

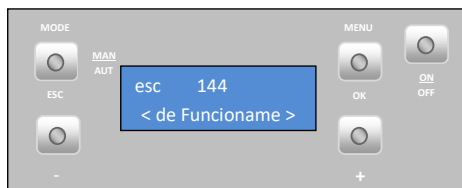

This menu indicates how many working hours the compact has after the last service. Number of hours the service should take place.

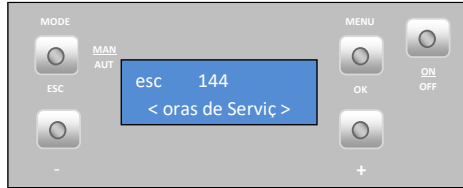

Very Important: When the machine is close to reaching its service hours it is recommended to call an accredited technician to perform maintenance on this.

The "Actuações" menu indicates the phase/status of the compact.

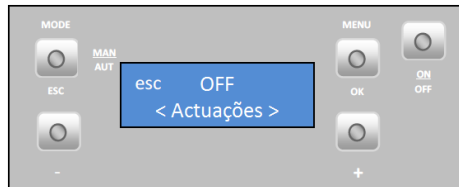

Operating speed (revolutions per minute) of the fume extractor.

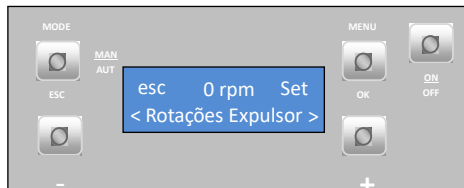

Air flow measured by the air sensor (Applied only to compacts 18 and 24).

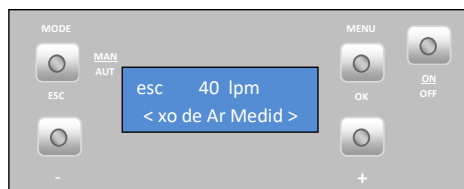

Theoretical pellet consumption.

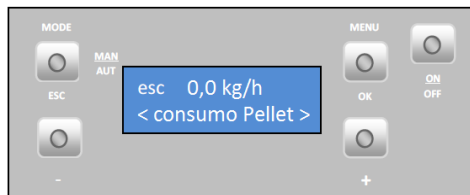

Fume temperature.

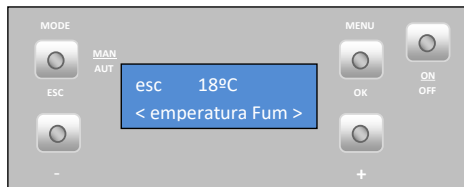

Pellet feeding time.

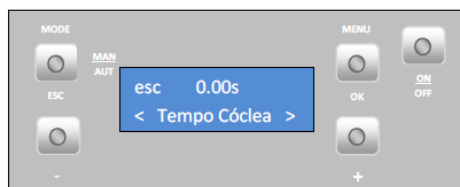

Compact water pressure.

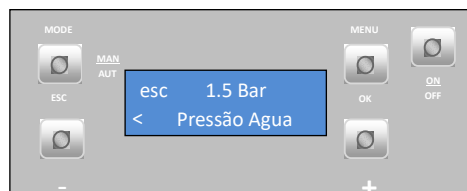

Press the "esc" key once and then "+" to go to the "configurações".

10.2.7. Configuration menu

To change the compact's **conFIGuretion** setup press "set". The "Língua" (Language) menu appears.

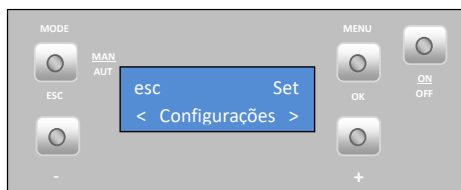

- Language

To select the **language**, press "set". Using the "+" or "-" keys, select the desired language (**Pt** – Portuguese; **Nl** – Dutch; **Gr** – Greek; **It** – Italian; **En** – English; **Fr** – French; **Es** – Spanish; **De** – German). Press "ok" to confirm.

Press the "+" key to go to the "eco" menu.

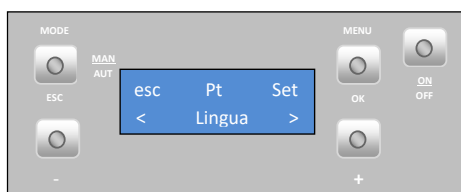

- Eco mode

If the compact is equipped with a thermostat that operates exclusively based on the temperature, the "eco mode" can be enabled to reduce the fuel consumption. In this mode, the compact operates at a set point temperature. The compact always operates at maximum operating power until it reaches a temperature of 33.8°F (1°C) above the set point temperature. Upon reaching this temperature, the unit starts operating at minimum operating power for a preset time period. After this time has elapsed, the unit turns off. It remains off for another preset period of time. When the measured room temperature drops to a preset value, the compact turns on again at the maximum operating power.

This operation is only available in automatic mode.

To activate the eco mode, press "set". The display starts to flash. Select "On" or "Off" using the "-" and "+" keys. Press "set" to confirm the selection.

Press "esc" to return to the previous menu and "+" to go to the "Iluminação" (Light) menu.

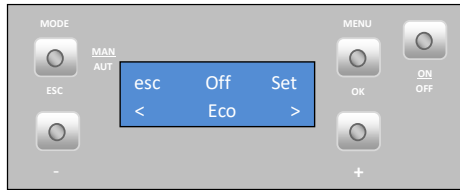

- Light

To select 'ecrã iluminado' (**lit screen**), press "set". The display starts to flash. Press the "+" or "-" key to select the time period during at which you want the screen to be light up, or choose "On" to keep the light permanently on. Press "ok" to confirm the selection. Press the "+" key to go to the "Tons" (Tones) menu.

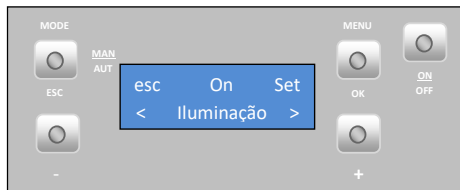

- Tones

To activate the **key tone**, press "set". The display starts to flash. Press the "+" or "-" key to select "On" or "Off". Press "ok" to confirm. Press the "+" key to go to the "°C/°F" menu.



- Temperature scale (°C/°F)

To select **°C / °F**, press "set". The display starts to flash. Press the "+" or "-" key to select "°C", "°F" or "Auto", and then "ok" to confirm. Press the "+" key to go to the "Receita Pellet" (Pellet Qty) menu.

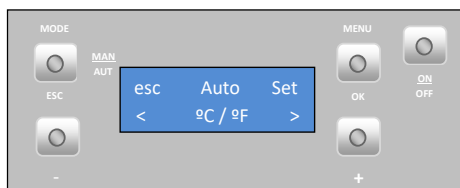

- Pellet quantity

Press "set" to show the "Actuações transitórias" (Temporary settings) menu.



- Temporary settings

This feature allows you to increase or decrease by 25% **the amount of pellets at start-up**. Press "set". The display starts to flash. Press "+" or "-" to increase or decrease (-5 to +5), as required. Each unit must be multiplied by 5 to obtain the correct percentage. Press "ok" to confirm the selection. Press the "+" key to go to the "Actuações de Potência" (Power settings) menu.

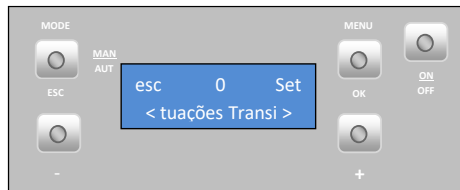

- Power settings

This feature allows you to increase or decrease by 25% the amount of pellets at each power level. Press "set". The display starts to flash. Press "+" or "-" to increase or decrease the setting (-5 to +5), as required. Each unit must be multiplied by 5 to obtain the correct percentage. Press "ok" to confirm the selection. Press "esc" to return to the "Receita de pellets" (Pellet Qty) menu and "+" to go to the "Termostato" (Thermostat) menu.

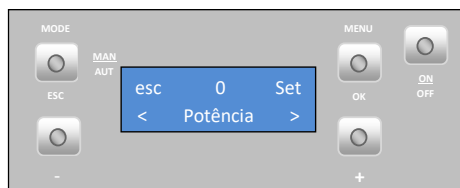

- Thermostat

This feature allows you to enable or disable the **room temperature thermostat**. Press "set". The display starts to flash. Press the "+" or "-" key to select "On" or "Off" and then "ok" to confirm. Press the "+" key to go to the "Carga Pellet" (Pellet loading) menu.



- Pellet loading

This feature allows you to enable the **worm drive** to fill the channel when it is empty to ensure lighting of the unit. Press "set"; the "ok" option appears. Press "ok" to activate the drive (the "habilitada" (Activated) message appears) and "esc" to stop it. Press the "+" key to go to the "Limpeza" (Cleaning) menu.

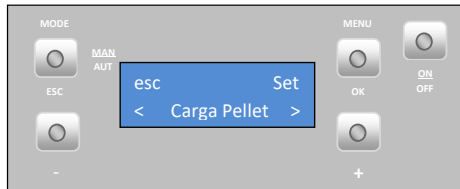

- Cleaning

This feature allows you to **clean** the burning basket manually. Press "set"; the "ok" message appears. Press "ok" to start the cleaning; the "Habilitada" (Activated) message appears. When you wish to stop, press "ok". Press the "+" key to go to the "Técnico" (Technical) menu.



The technical menu is not available to the end user since it only includes factory settings that must never be changed.

10.2.8. Technical Menu

This feature allows the user to adjust the unit's different variables. Pressing "set" displays the "password" menu to enter the technical menu.

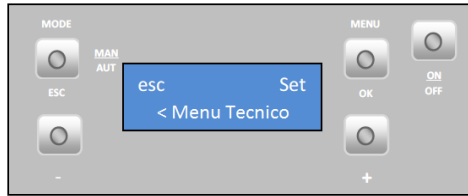

Press "Ok"; the letter "A" starts to flash. Using the "+" and "-" keys, select the desired letter. Press "Ok" to confirm; the numbers "00" start to flash. Using the "+" and "-" keys, select the desired number. Confirm by pressing "OK" to go to the "ConFigueção" ("Settings") menu.

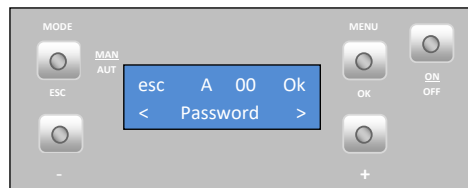

Note: The password is only provided to authorised technicians.

11. Alarm / Failure / Recommendation List

Alarm	Code		Troubleshooting
Ignition failure	A01	Maximum time 900 sec	<ul style="list-style-type: none"> - The worm drive channel is empty - restart the unit - Resistance burnt - replace resistance - The burning basket has been incorrectly installed - Worm locked - unlock - Smoke temperature did not exceed the value set at captivation
No flame or lack of pellets	A02	Temperature under: 140°F (60 °C)	<ul style="list-style-type: none"> - Pellet reservoir is empty
Excess heat in the pellet drum	A03	194°F (90 °C)	<ul style="list-style-type: none"> - The fan is not working - call for assistance - Faulty thermostat - call for assistance - Machine with faulty ventilation
Excess fume temperature	A04	Over 554°F (290°C)	<ul style="list-style-type: none"> - The fan is not working or is working at a low power level - increase the level to the maximum (if the problem persists, call for assistance) - Insufficient extraction - Excess pellets - Faulty smoke probe
Pressure switch alarm	A05	The door is open, lack of draught or extractor fault for 180 sec	<ul style="list-style-type: none"> - Close the door and clear the error message on the faulty pressure regulator - Obstruction of the exhaust pipe or faulty extractor
Air mass probe	A06	40 Ipm delta for 900 sec	<ul style="list-style-type: none"> - Pipes with insufficient extraction or obstructed pipes
The door is open	A07	Door open for 120 seconds	<ul style="list-style-type: none"> - Close the door - clear the error message - Faulty air mass sensor
Fume extractor is faulty	A08	Connection failure	<ul style="list-style-type: none"> - Check connection - Check that the fan is not blocked
Fume probe failure	A09	Connection failure	<ul style="list-style-type: none"> - Check connection
Pellet resistance error	A10	Connection failure	<ul style="list-style-type: none"> - Check connection - Faulty resistance
Worm drive error	A11	Connection failure	<ul style="list-style-type: none"> - Check connection - Faulty auger motor
Pellet level alarm	A15		<ul style="list-style-type: none"> - Check connection
Water pressure outside operating range	A16		<ul style="list-style-type: none"> - Check connection
Excess water temperature	A18		<ul style="list-style-type: none"> - Check connection

Table 2 - List of Alarms

 Important note: all alarms cause the machine to shut down. The alarm must be reset and restarted. To reset the unit press the "On/Off" button for 10 seconds until the alarm sounds.

- Failures

Failures
Manutenção "service"
Falha no sensor de massa de ar
Baixo nível de pellets
Porta aberta
Falha no sensor de temperatura de ar
Falha no sensor de temperatura de água
Falha no sensor de pressão de água
Pressão de água próxima dos extremos do intervalo de funcionamento

Table 3 - List of failures

 Important notice: A "**service**" warning on the display (maintenance due) indicates that the unit has exceeded 2100 operating hours. In this case, the client must perform the unit's maintenance procedure (following the instruction on the Technical Manual). Once this procedure is completed the hour meter may be reset, to clear the warning message. This message does not impact the normal operation of the unit. It is simply a warning.

 Important notice: The errors can be reset only when the error information is flashing on the display. To reset the error, press the "Mode" button once while displaying the error.

 Important note: when alarm "A16" occurs, you can check the pressure value read by the compact. To do so, press the "Mode" button for 10 seconds to access the normal compact menus, and then you have 2 minutes to access the "user info" menu and check the pressure value read by the compact.

 **WARNING!**

In case of an emergency, turn off the unit by following the normal shutdown procedure.

 **WARNING!**

THE UNIT BECOMES HOT DURING OPERATION SO CARE MUST BE TAKEN ESPECIALLY WHEN HANDLING THE DOOR GLASS AND DOOR HANDLE.

12. Columbus Electronics

Solzaima compacts may be equipped with Columbus electronics, the Columbus display is as shown below. To confirm if your equipment is equipped with these electronics, you should check the equipment's serial number and consult Table 4.

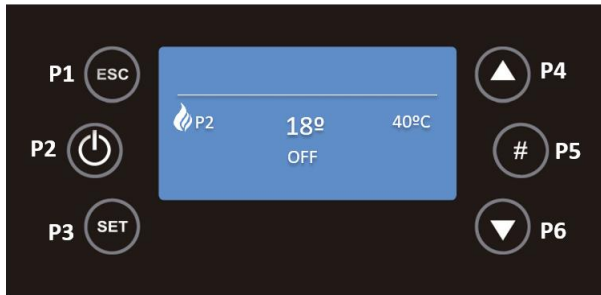

Columbus Electronics	Equipment Serial Number
Compacta Eco 12	≥ 01-24-00048
Compacta Eco 18	≥ 01-24-00127
Compacta Eco 24	≥ 01-24-00169

Table 4 - Serial Number with Columbus Electronics



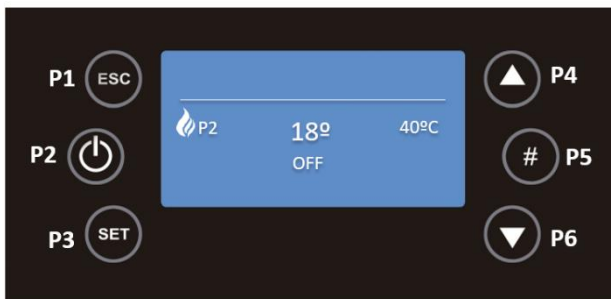

12.1. Display

When the unit is connected to electricity, the display indicates the "OFF" status of the compact, and can also indicate chrono activation, system errors, selected combustion power, selected ventilation power, current room temperature, and selected room temperature set-point.



In the Input Menu by pressing the key:

- "P1" it is possible to exit the menu/submenu;
- "P2" it is possible to turn on the equipment, or, turn off the equipment. The same button allows the reset of errors in case of blockage by pressing 3 seconds continuously, it also allows the activation of Crono in the corresponding submenu;
- "P3" it is possible to access the user menu 1, by pressing 3 seconds on the same button we can access the user menu 2 and it also allows saving changes;
- "P4" it is possible to enter the Combustion Power menu;
- "P5" it is possible to enter the Information menu and also activate an hourly interval of the Chrono;
- "P6" is possible to enter the Room Thermostat menu;
- "P3" + "P5" for 3 seconds it is possible to enter the secondary information menu present in the service menu where it is possible to check a set of variables.

Led	Meaning
D  S  FS 	<ul style="list-style-type: none"> • When this LED is active it means that the Chrono is in Daily Mode ON, Weekly Mode ON, or Weekend Mode ON.
	<ul style="list-style-type: none"> • When this LED is active, it indicates which fans are running, local and remote.
	<ul style="list-style-type: none"> • When this LED is active, it means that the requested room temperature has already been reached.



THE INSERTABLE MUST ALWAYS BE DEACTIVATED BY THE SAME METHOD THAT IT WAS ACTIVATED. DURING THE ACTIVATION PROCESS THE EQUIPMENT MUST NEVER BE DISCONNECTED.

12.2. Settings Menu

12.2.1. Language

By pressing the P3 key for 3 seconds, you will then see the Settings, Service, Keypad and System Menu menus.

THE LATTER IS AN EXCLUSIVE MENU FOR THE TECHNICAL SERVICE AND REQUIRES A PASSWORD TO ACCESS IT.

With the P4 and P6 keys you must select the desired menu and then press P3 to validate the choice, in this case the Settings menu.

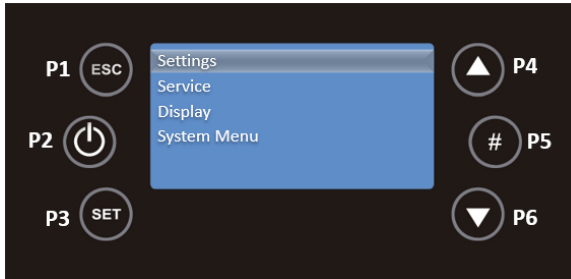

Select the Language submenu with the P6 key and to validate the entry in this submenu the P3 key.

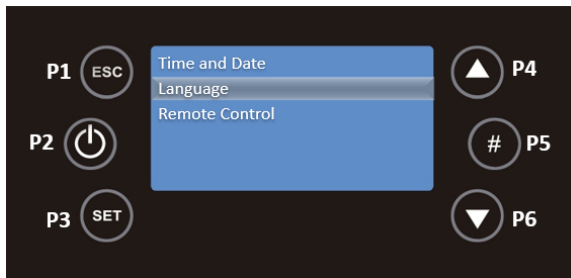

Within this submenu, with P4 and P6 select the desired language and press the P3 key again to validate.

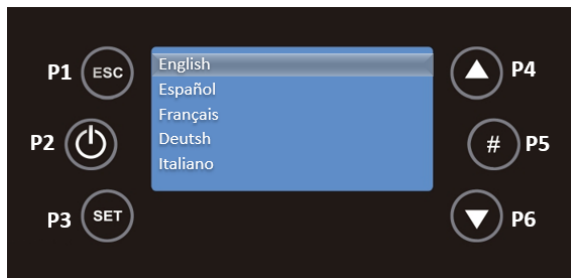

To exit the Language menu you must press the P1 key.

12.2.2. Date and Time

- Time

In the main screen, by pressing the P3 key for 3 seconds, you can access the Settings menu, and press P3 again to enter this menu.

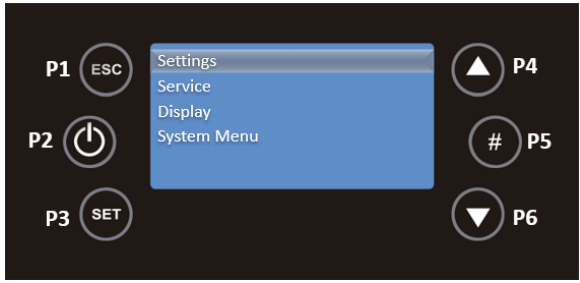

With the P3 key, select Date and Time.

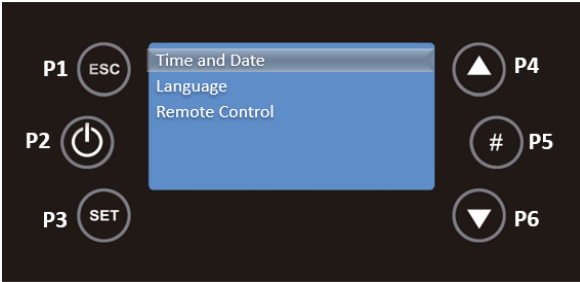

Now in the Date and Time menu, select Time, with the P4 and P6 keys, and press the P3 key, the time will appear in editable mode, flashing, with P4 and P6 select the correct time and press P3 to validate.



The same must be done for Minutes, with P6 select Minutes and press P3, the minutes will appear in editable mode, flashing, with P4 and P6 select the correct minutes and press P3 to validate.



- **Date**

In the same menu, select Day with the P4 and P6 keys and press P3, the day will appear in editable mode, flashing, with P4 and P6 select the correct day and press P3 to validate.

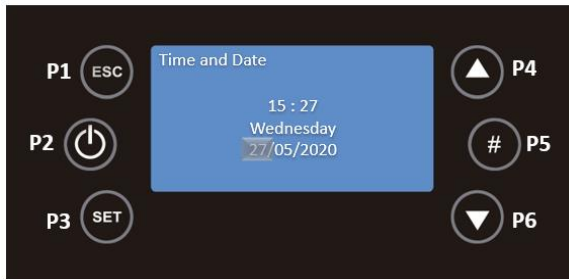

To edit the Month you must use the P4 and P6 keys to select this field and then P3, the month will appear in editable mode, with P4 and P6 select the desired month and press P3 again to validate.



The Year follows the same procedure, press the P4 and P6 keys to move to the Year, use the P3 key to edit this field, the year will appear in editable mode. With P4 and P6 select the desired year and press P3 to validate.



THE DAY OF THE WEEK (SUNDAY TO SATURDAY) CHANGES ACCORDING TO THE SELECTED DAY OF THE WEEK.

12.2.3. Remote Control

In the main screen, by pressing the P3 key for 3 seconds, you can access the Settings menu, and press P3 again to enter this menu.

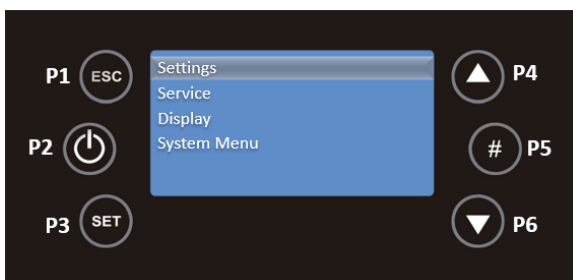

With the P6 key select the Remote Control submenu and to validate the entry in this submenu the P3 key.

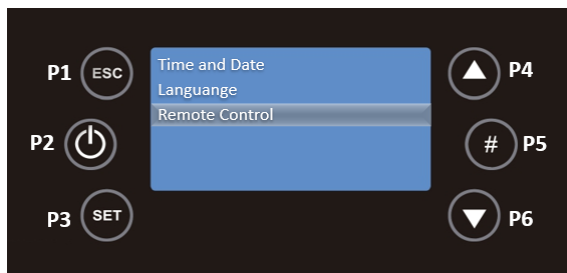

With the P4 and P6 keys you can activate or deactivate the Remote Control, pressing P3 to validate the action.

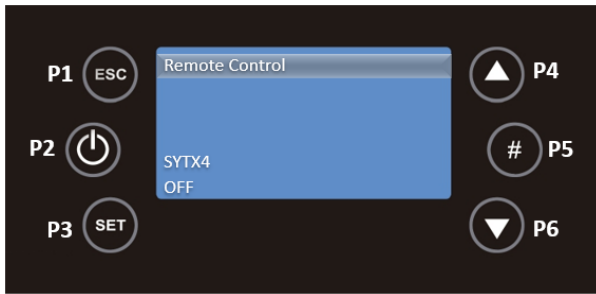

12.3. Display Menu

By pressing the P3 key for 3 seconds, you will see the menus Settings, Service, Keypad and System Menu. With the P4 and P6 keys you must select the desired menu and then press P3, to validate the choice, in this case the Keyboard menu.

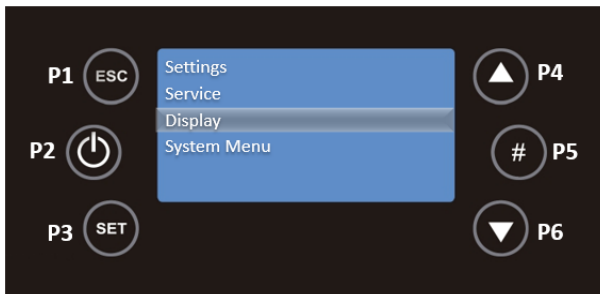

In this menu there are the functions Contrast, Min Brightness, Screen Saver and Firmware Codes.

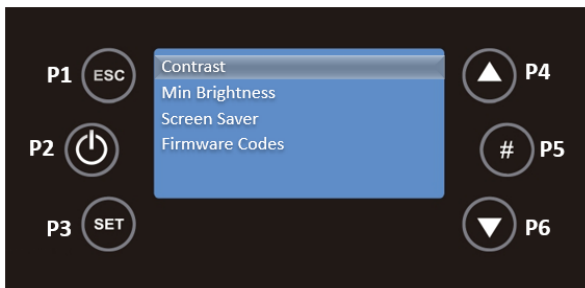

12.3.1. Contrast

By pressing the P3 key to validate the choice of this function, with the P4 and P6 keys you can set the contrast between 0 and 30 for your screen. To return to the Keypad menu, press P1.

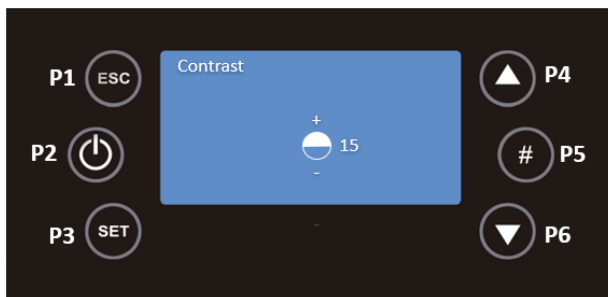

12.3.2. Min Brightness

In the Keypad menu with P4 and P6 select the Min Brightness function by pressing on the P3 key. With the keys P4 and P6 you can set the brightness between 0 and 20 for your display. To return to the Keypad menu, press P1.



12.3.3. Screen Saver

In the Keypad menu with P4 and P6 select the Screen Saver function by pressing on the P3 key. In this function you can activate or deactivate the screen lock. To return to the Keypad menu, press P1.

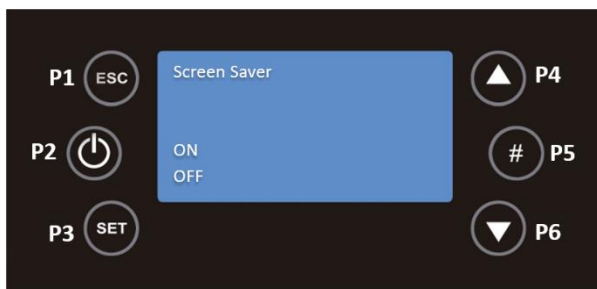

12.3.4. Firmware Codes

In the Keypad menu with P4 and P6 select the Firmware codes function by pressing on the P3 key. This function, for reference only, allows you to see the communication address of the control board, the board type and firmware version.

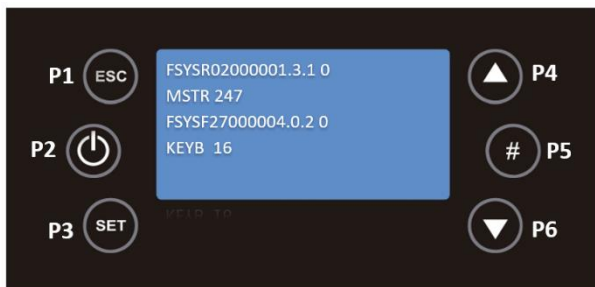

To return to the Keypad menu, press P1. Pressing this key twice brings up the menus Settings, Keypad, Service and System Menu.

12.4. Service Menu

By pressing the P3 key for 3 seconds, you will see the menus Settings, Service, Keypad and System Menu. With the P4 and P6 keys you must select the desired menu and then press P3, to validate the choice, in this case the Service menu.

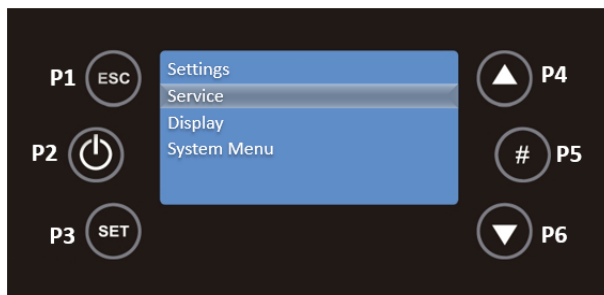

In this menu you have the following functions.

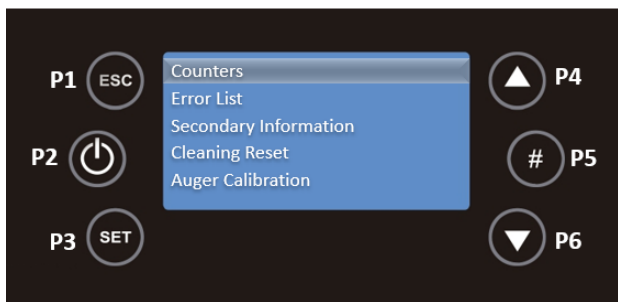

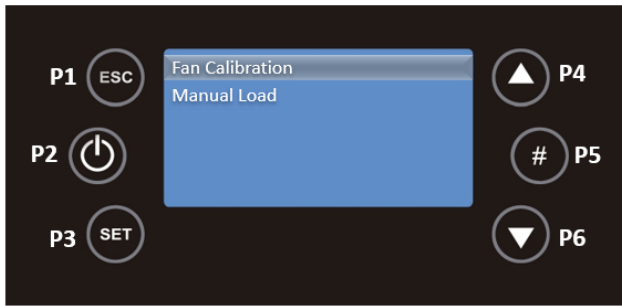

12.4.1. Counters

Select Counters, with the P3 key, to validate the entry in this submenu. This function allows you to query the working hours, the number of ignitions and the number of failed ignitions.

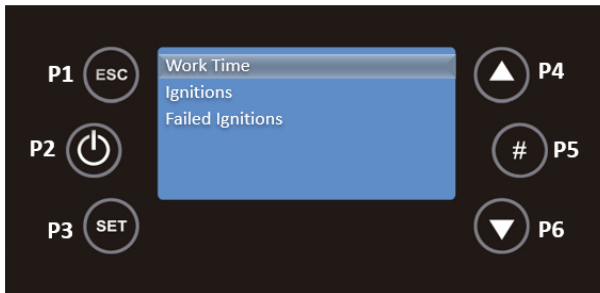

With the P4 and P6 keys, select the submenu you wish to consult and press P3 to validate. To return to the Service menu, press P1.

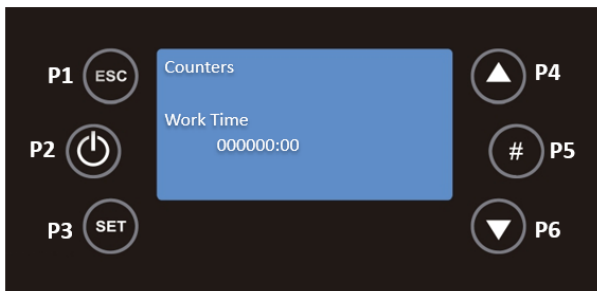

12.4.2. Error List

In the Service menu with P4 and P6 select the submenu Error List, pressing the P3 key to validate.

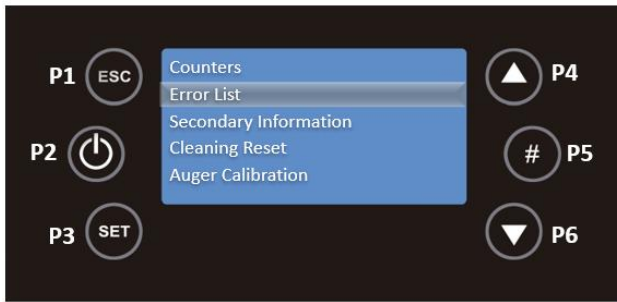

This submenu shows the last 10 errors that occurred, on each line the error code and the date and time when it occurred are shown. To return to the Service menu, press P1.

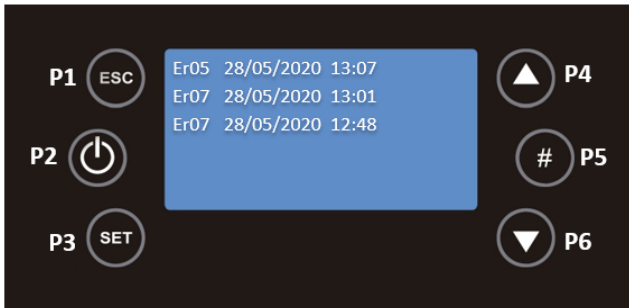

12.4.3. Secondary Information

In the Service menu, select the Secondary Information submenu with P4 and P6, and then press the P3 key.

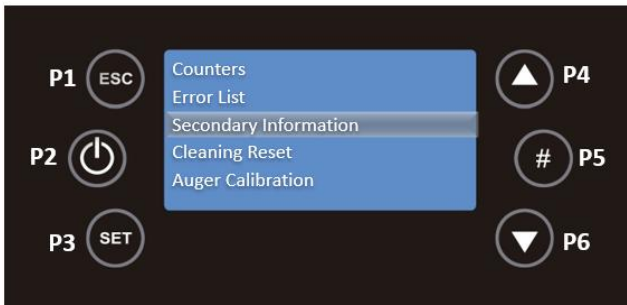

In this function you can query the product code, the status of the fume extractor, the worm, the ambient fan, and the status of the outputs.

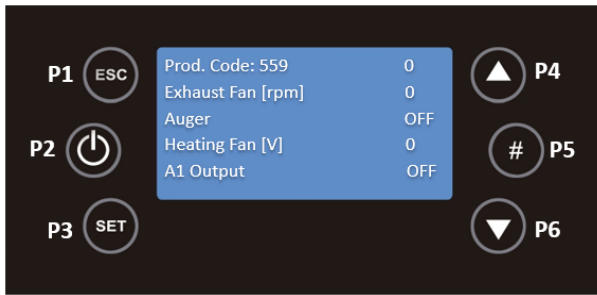

It is possible to query the fume temperature, room temperature and the state of the inputs. Whether the state of the input is open (0) or closed (1).

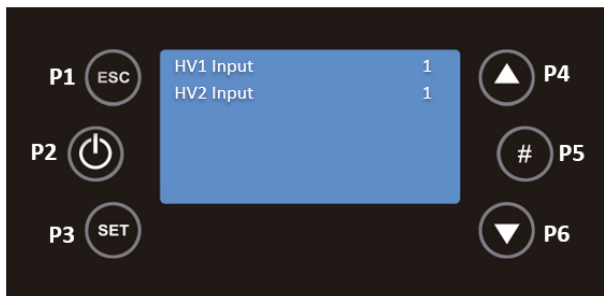
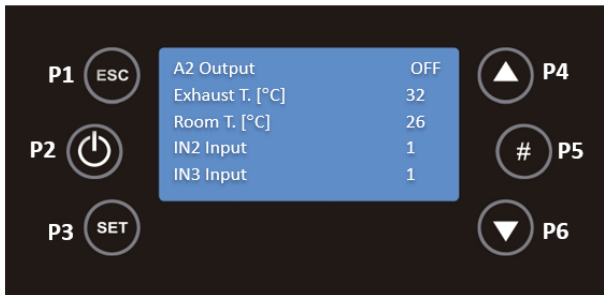

12.4.4. Cleaning Reset

In the Service menu with P4 and P6 select the Reset Cleaning function by pressing on the P3 key.

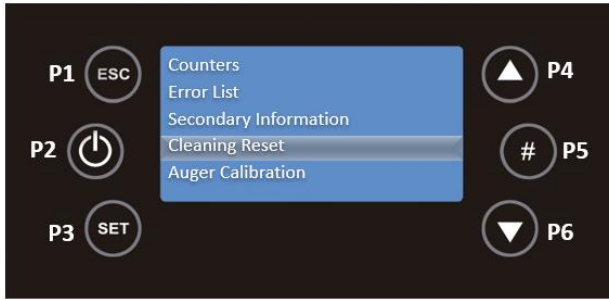

In this function you can turn this function on or off. To return to the Service menu, press P1.

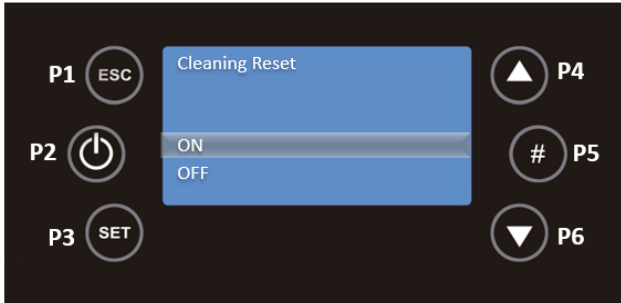

12.4.5. Auger Calibration

In the Service menu with P4 and P6 select the Cochlea Calibration submenu, pressing the P3 key to validate.

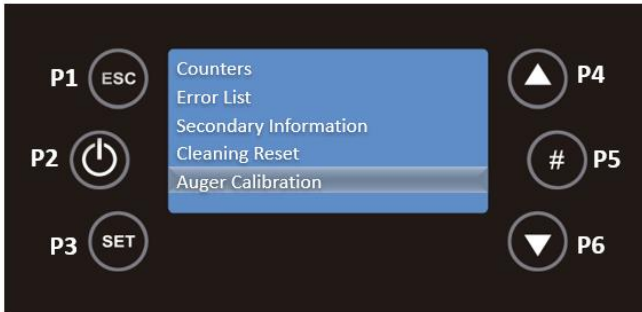

In this submenu with the keys P4 and P6 you can adjust the amount of pellets to be fed, between -7 (-14%) and 7 (+14%). To return to the Service menu press P1.

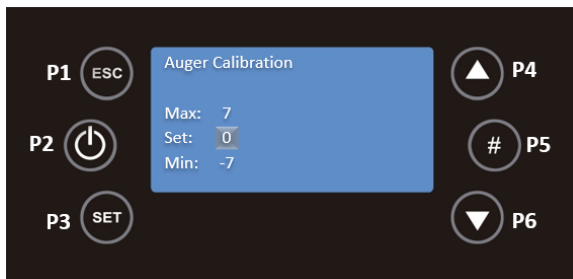

12.4.6. Fan Calibration

In the Service menu with P4 and P6 select the submenu Fan Calibration by pressing on the P3 key.

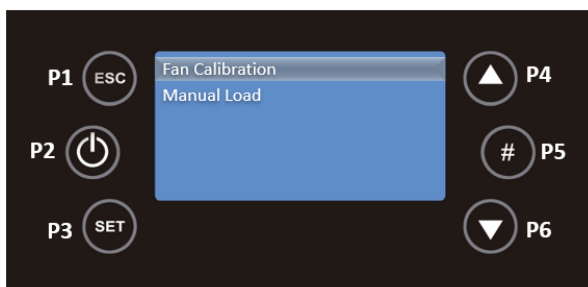

In this submenu with the keys P4 and P6 you can adjust the fan speed, between -7 (-21%) and 7 (+21%). To return to the Service menu press P1.

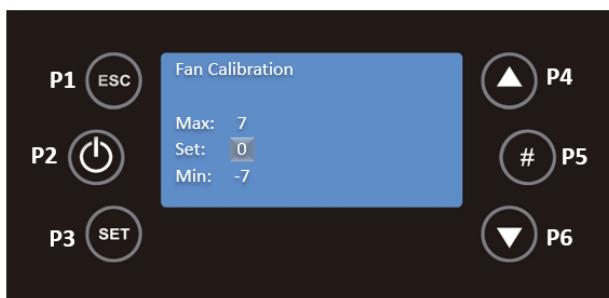

12.4.7. Manual Load

Select Manual Load, using the P3 key, to validate the entry in this submenu.

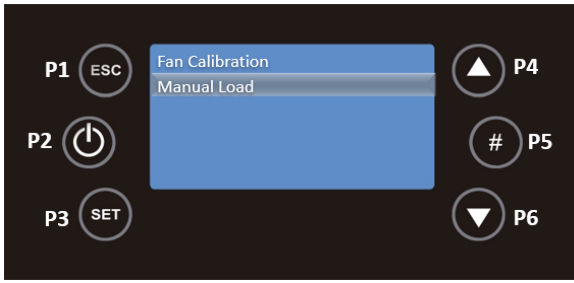

This function activates manual pellet loading.

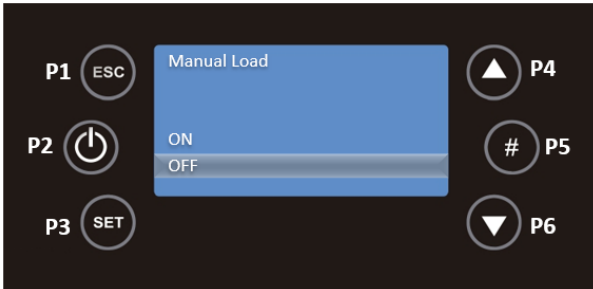

By pressing the P1 key twice, you will return to the main menus, Settings, Display, Service, and System Menu.

THE LATTER IS AN EXCLUSIVE MENU FOR THE TECHNICAL SERVICE AND REQUIRES A PASSWORD TO ACCESS IT.

12.4.8. Automatic Power

In the Service menu with P4 and P6 select the Automatic Power submenu by pressing on the P3 key.

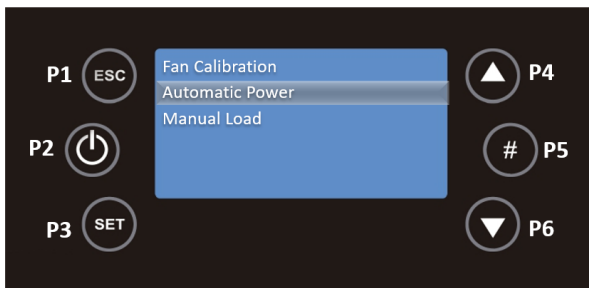

In this submenu you can set the firing power only in automatic mode. If you set it, all power change menus will not be visible. With P4 and P6 you must select On or OFF and validate your choice with the P3 key.

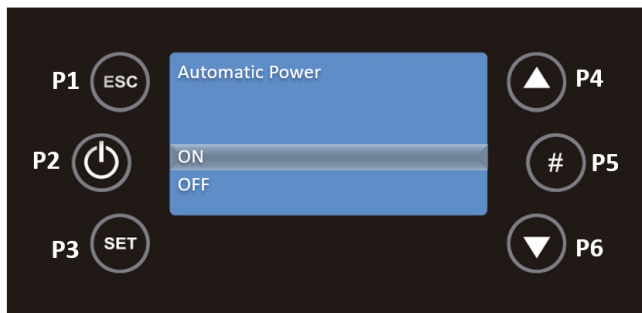

12.5. Power Menu

Pressing the P3 key accesses the following menus, Power, Thermostats and Chrono. With the P4 and P6 keys you must select the desired menu and then press P3 to validate the choice, in this case the Power menu.

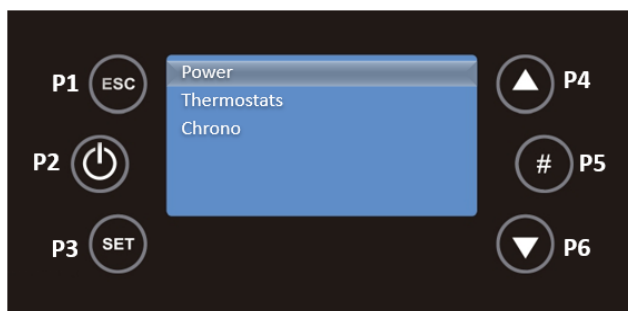

12.5.1. Pellet

Select Pellet with the P3 key, to validate the entry in this submenu.



With the P4 and P6 keys you can modify the combustion power of the system. Press the P3 key to save your changes and use P1 to go back.



12.6. Thermostats Menu

Press the P3 key to access the Thermostats menu, using the P6 key, and then press P3 to validate the choice of this menu.

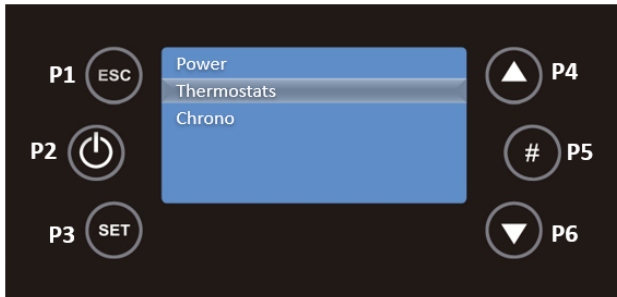

In this menu, select the submenu Compact, using the P3 key.

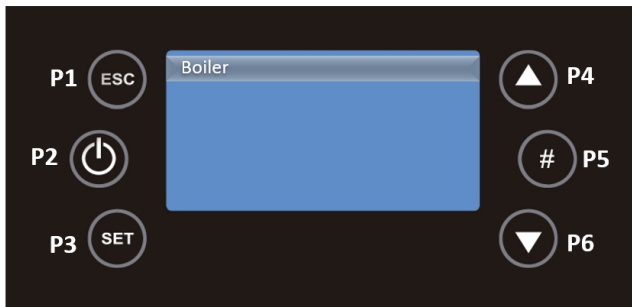

This submenu allows you to change the value of the Compact thermostat, with the P4 and P6 keys. The minimum and maximum values can be programmed.

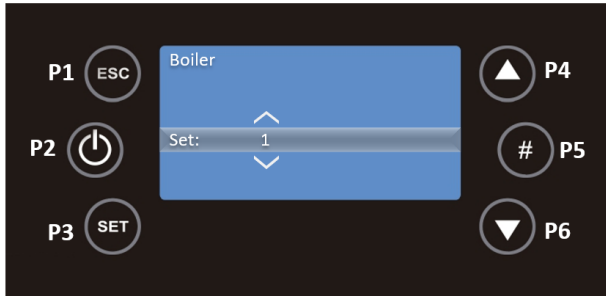

Press the P3 key to save your changes and use P1 to go back.

12.7. Chrono Menu

The equipment has a time scheduler that is used to automatically turn the insertable on and off. It can be daily (you can select the day of the week you want and set up to 3 different times for the respective day), weekly (you can select up to 3 times during a day, the same program will be applied every day of the week) and weekend (you can select 3 times during the day for weekdays and weekends).

In the main screen, pressing the P3 key accesses the menus, Power, Thermostats and Chrono. With the P4 and P6 keys you must select the Chrono menu and then press P3, to validate your choice.



Then you must enter the Program submenu, using the P6 key to select and P3 to validate the choice.

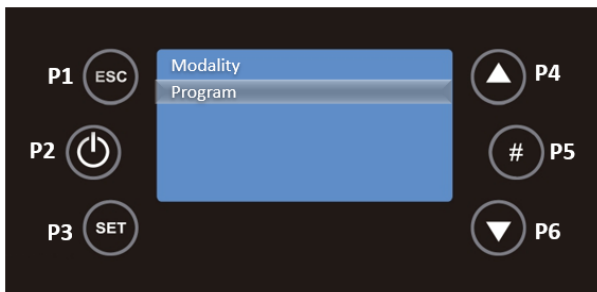

Then with the P4 and P6 keys you must select Daily, Weekly or Weekend. You must press P3 to validate the choice.

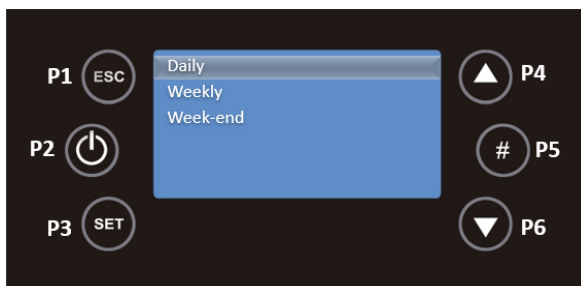

For the Daily program you must, with the P4 and P6 keys, select the day of the week, in this case the program for Monday, and then press P3 to validate the choice.

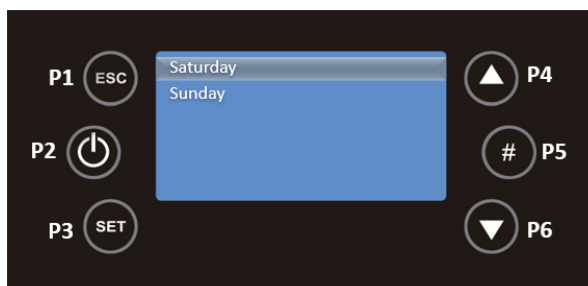
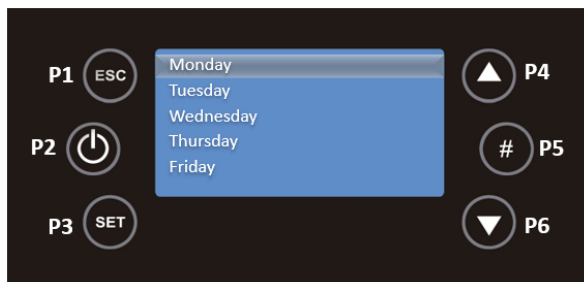

You should press P3 and this field will be in editable mode, flashing. Press P4 and P6 to select the desired time and then use the P3 key to save. You must repeat this process for the time at which the equipment should shut down, with the P4 and P6 keys. Finally you must captivate the interval with the P5 key, and a check mark will appear on the right side of the interval.



In the image above the system will turn on at 20:30 on Monday and turn off at 06:30 on Tuesday. When programs are developed around midnight with the intention of starting operation the day before and ending operation the next day it will be pertinent:

- End the last program on the previous day by 23:59;
- Start the first program the next day by 00:00.

For the Weekly program, the programs are the same for every day of the week, from Monday to Sunday. You must, with the P4 and P6 keys, select Weekly, in the Program submenu, and press P3 to validate the choice.

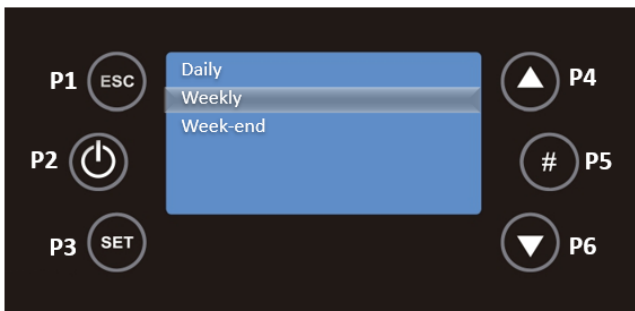

You should press P3 and this field will be in editable mode, flashing. Press P4 and P6 to select the desired time and then use the P3 key to save. You must repeat this process for the time at which the equipment should shut down, with the P4 and P6 keys. Finally you must captivate the interval with the P5 key, and a check mark will appear on the right side of the interval.



For the Weekend program, you must, with the P4 and P6 keys, select Weekend and press P3 to validate your choice.

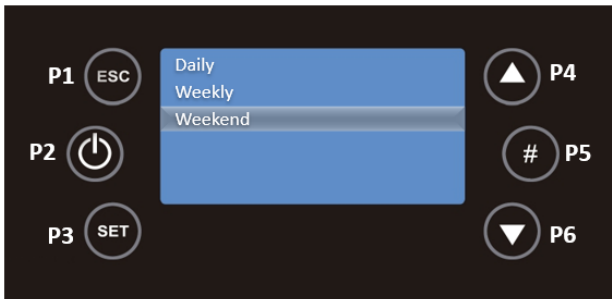

For this mode you must choose between the Monday to Friday and Saturday to Sunday time slots by pressing the P3 key.

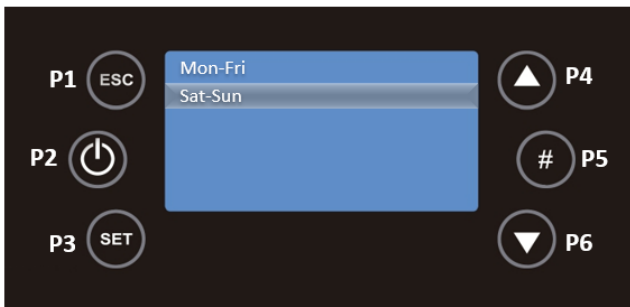

You should press P3 and this field will be in editable mode, flashing. Press P4 and P6 to select the desired time and then use the P3 key to save. You must repeat this process for the time at which the equipment is to turn off, with the P4 and P6 keys. Finally you must activate the interval with the P5 key, and a check mark will appear on the right side of the interval.

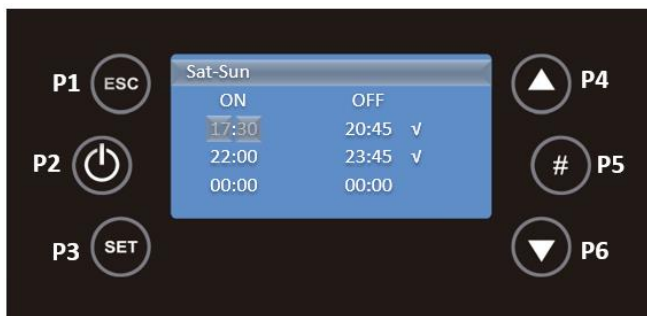

AFTER DEFINING THE PROGRAMS IT IS NECESSARY TO DEFINE WHICH MODE YOU WANT TO ACTIVATE.

In the main screen, press the P3 key to access the menus, Power, Thermostats and Chrono. With the P4 and P6 keys you must select the Chrono menu and then press P3, to validate the choice.

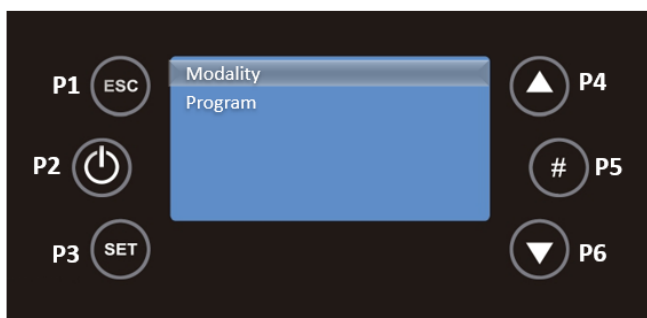

By selecting Mode with the P3 key you can select which chrono mode you want. Use the P4 and P6 keys to select between Daily, Weekly, or Weekend, use the P2 key to activate/deactivate the choice, and P3 to save the changes.

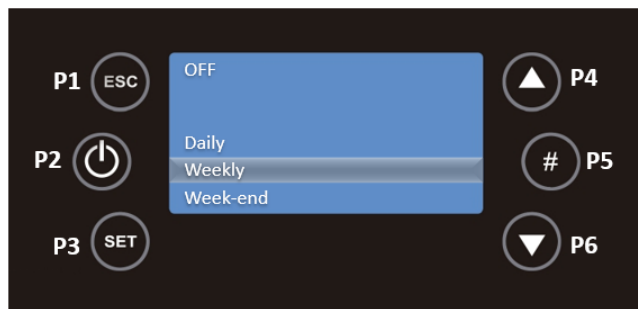

The main screen after activating the mode gets Led D, S or FS active in the upper right corner.

12.8. User Info

In this menu the user can view some information about the equipment, such as measured values and aspects concerning the electronics. In the initial menu, press the P5 key once, and the menu will appear.

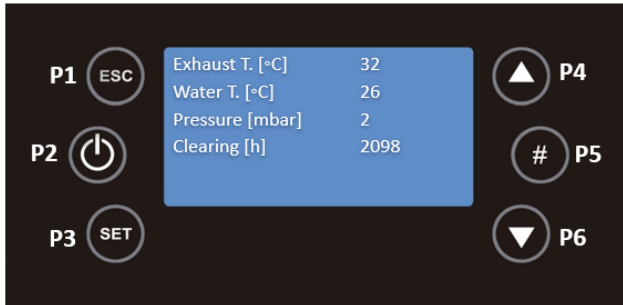

With the P4 and P6 keys you can scroll through the different variables. The values displayed are the values measured On-Line.

The following table is explicit to the meaning of each of the variables.

T. Smoke [°C]	Read in degrees Celsius (°C) it tells you the exhaust temperature monitored by the thermocouple.
Water Temperature [°C]	Read in degrees Celsius (°C) it tells you the water temperature.
Extractor [rpm]	Read in revolutions per minute, it tells you the rotation speed of the extractor.
Auger Motor [s]	Read in seconds, this tells you the time within a 4-second period that the worm motor is active and feeding pellets to the burner.
Service [h]	Read in hours informs the number of hours missing to report anomalies due to lack of maintenance. These must be calibrated by the technical service during maintenance. The maintenance period must respect the kilos of burned pellets
Working Time [h]	Read in hours tells you the number of hours in On, modeling, and security.
Ignitions [nr]	Read in number of occurrences tells you how many ignitions have been performed since they were fired.
Artic. Code	Product Code.

13. List Alarms / malfunctions / recommendations – Columbus Electronics

To turn the device off, in case of emergency, you must perform the normal shut down of the equipment. To do this you must press the off button for 3 seconds and allow the deactivation until the word off appears on the display.

All alarms cause the machine to shut down with information about the error and activation of the alarm led. It will be necessary to reset the alarm and restart. To reset the machine, press the "On/Off" button for 3 to 4 seconds until you hear a beep, accompanied by the message "Reset alarms in progress";

If the reset is successful, there will be new information - Reset alarms successful.

In the Off state if for any reason the smoke temperature rises above 85°C (Th01) the stove enters the off mode.

Code	Alarm	Cause and Resolution
Er01	Excess temperature in the pellet tank	<ul style="list-style-type: none"> - Room fan not working - call for service - Thermostat defective - call for service - Machine with defective ventilation
Er02	Smoke pressure switch alarm	<ul style="list-style-type: none"> - Close the door and remove the faulty pressure switch error - Faulty exhaust pipe obstruction or extractor
Er03	Exhausted flame or lack of pellets	<ul style="list-style-type: none"> - Empty pellet tank; - Broken thermocouple; - Clogged pellet channel
Er05	Excess temperature fumes	<ul style="list-style-type: none"> - Room fan does not work or is at a low power level - increase the level to maximum (if the problem persists call for service) - Insufficient draft - Excessive dosage of pellets - Defective smoke probe
Er07	Fume extractor error	<ul style="list-style-type: none"> - Check connection - Check that the fan is not blocked - After fault correction it is necessary to reselect operation mode P25=2

Er08	Fume extractor encoder error	<ul style="list-style-type: none"> - Exhaust pipe obstruction or extractor defective - After fault correction it is necessary to reselect operating mode P25=2
Er12	Ignition failure	<ul style="list-style-type: none"> - Empty worm channel - restart - Burned out heating element - replace heating element - Firing basket incorrectly placed - Fume temperature did not exceed the value set at switch-on
Er15	Power supply voltage cut-off	<ul style="list-style-type: none"> - Check supply voltage with the electric power supplier; - Check simultaneous use of electrical appliances - In case of a short power failure (<10s) the insert continues to work normally; - If the system was ON and the power supply failure occurs for more than 10s and less than 50 min the insertable develops an ignition after blackout
Er16	Faulty communication with LCD control	<ul style="list-style-type: none"> - Check connection between board and display
Er39	Pressure differential sensor damaged	<ul style="list-style-type: none"> - Check connection between plate and pressure differential sensor; - Check pressure differential reading - Check possible clogging in the measurement taps, or throttling of the same
Service	Maximum value / reference for the differential sensor reached	<ul style="list-style-type: none"> - Contact your installer or repairer for occasional preventive maintenance of the equipment.

THE MAINTENANCE FAULT (MESSAGE "SERVICE" ON THE DISPLAY) MEANS THAT THE STOVE HAS MORE THAN 2100 HOURS OF SERVICE. THE CUSTOMER MUST HAVE THE EQUIPMENT SERVICED AND ONLY THEN RESET THE HOUR METER TO CLEAR THE ANOMALY MESSAGE. THIS DOES NOT INFLUENCE THE NORMAL OPERATION OF THE EQUIPMENT, IT IS ONLY A WARNING.

 **WARNING!**

TO TURN THE DEVICE OFF, IN CASE OF EMERGENCY, YOU MUST DO THE NORMAL SHUTDOWN OF THE EQUIPMENT.

 **WARNING!**

THE EQUIPMENT WILL BE HOT DURING OPERATION, SO CARE MUST BE TAKEN, ESPECIALLY ON THE DOOR GLASS AND THE DOOR OPENING HANDLE.

14. Operating the unit

14.1. Starting-up the unit

To start operating the Free-Standing Pellet Fire unit, press the start/stop button for 3s. The display should indicate "Lighting" until this completion of this phase.

The *pellets* are fed through the supply channel to the burning basket (combustion chamber), where they will be ignited using a heat resistor. This process may take between 5 and 10 minutes, depending on whether the worm screw used to push through the *pellets* has been previously filled with fuel or is empty. Upon completion of the ignition phase, the word "On" should appear on the *display*. The heating power can be adjusted at any time by pressing the power selection button for approximately 1 second. You can choose between five pre-set power levels. The selected power is indicated on the display. The initial power status at each start-up will correspond to the power level set during the last cycle operation.



Important note: before starting the machine, check if the deflector plate is correctly positioned.

14.2. Stop

The stop sequence of the unit is started by pressing the start/stop key for 3s. The display will show "**Desactivação**" (Disabling) until full completion of this phase. The extractor will remain active until the fume temperature of 40°C is reached, to guarantee that all the material has been burnt.

14.3. Turning off the unit

The unit should only be disconnected after its full stop. Make sure that the display shows "**Off**" before disconnecting the unit. If necessary, disconnect the power cable from the mains.

15. Instructions for removing the side covers

15.1. Removing the side covers

Lift the cover and pull it up and forward to remove it from the top and front slots. The assembly is done the other way around.



Figure 16 – Removing the side covers

15.2. Pellet hopper lid

The pellet tank is opened by moving the lock sideways (Figure 17-a) and lifting the lid (Figure 17-b).

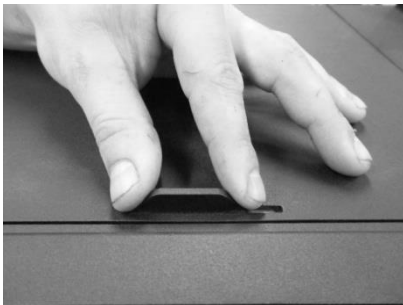

a)

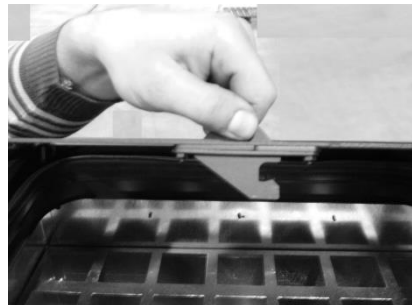

b)

Figure 17 – Lid opening

15.3. Replenishing the pellet tank

- 1 – Open the pellet hopper lid, in the upper area of the machine, as shown in Figure 17-b.
- 2 – Pour the bag of pellets into the tank, as shown in Figure 18.



Figure 18 – Replenishment of the pellet tank

3 – Turn on the equipment and close the tank lid by pressing it, as shown in Figure 17-a.

16. Installation and operation with external control (chronothermostat) – not included in compacts

The compact pellets are produced as standard with the control (display). Alternatively, the compact can be used with the application of a generic external control (chronothermostat).

Note: as a rule, the external control comes with a manual. To use the external control it is necessary to fit an interface (Figure 19-b).



a)

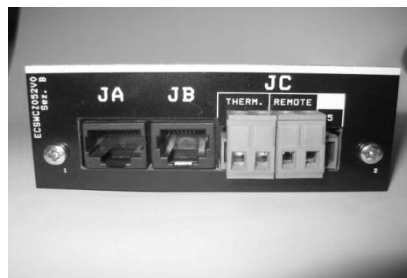

b)



c)

Figure 19 - External control (chronothermostat) and connection interface - both not included

This board has two inputs: "remote" and "thermostat". By connecting the chronothermostat to the "remote" input, the user gives the order to start (contact closed NC) and stop (open contact NO).

In case of connecting to the "thermostat" input it will only vary the power of the machine between minimum power (open contact NO) and maximum power (closed contact NC).

Note: In the case of the **wireless remote control**, it is necessary to connect the two wires, as indicated in the following figure:

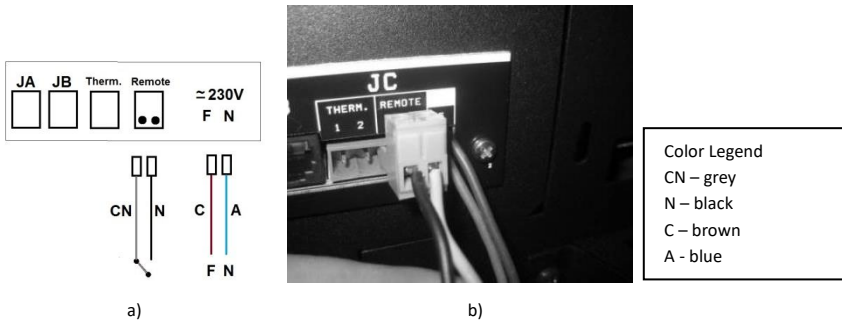

Figure 20 - Wireless Remote Control Connection

In the case of the **wired remote control**, it is necessary to connect the black and gray wires to the receiver as shown in the following figure:

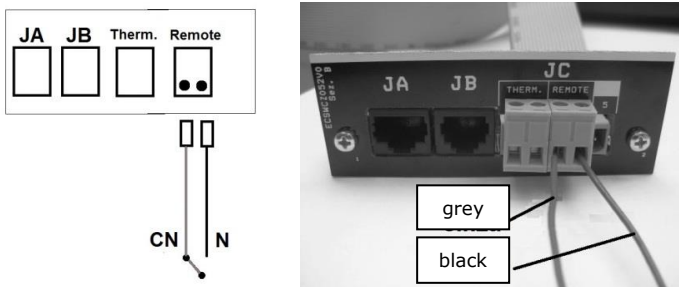
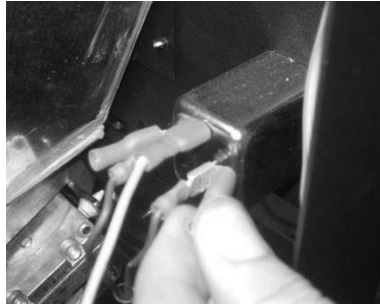

Figure 21 - Wired external control connections

16.1. Instruction four mounting the external control unit

- 1 – Turn off the machine at the main switch, remove the right side of the compact pellet.
- 2 – Remove the terminals of the machine's phase (F) and neutral (N) terminals.



a)

- 3 – Crimp the terminals of the cable that supplies 220V to the emitter.

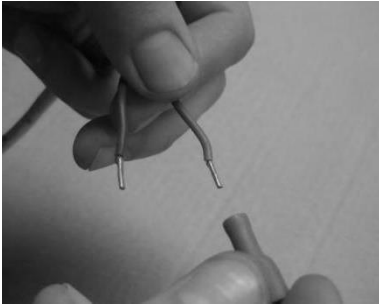

b)



c)

- 4 – Connect the wires to the ON/OFF contact connector (*Figure 22-d*); Run the wires through the cable gland, into the Compact (*Figure 22-e*).

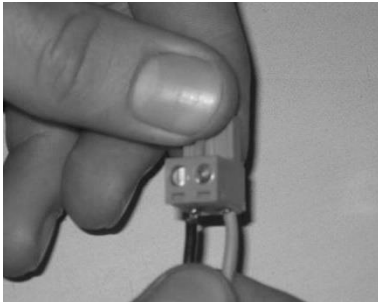

d)



e)

5 - Connect the external control plug (On/Off contact) in the "remote" position (Figure 22 -g).

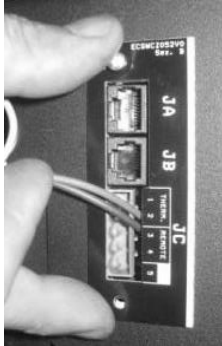

f)

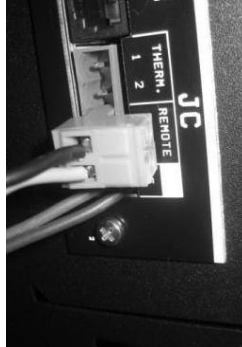

g)

6 - Connect the interface cable to the electronic board, on the communication plug (Servizi 5J).

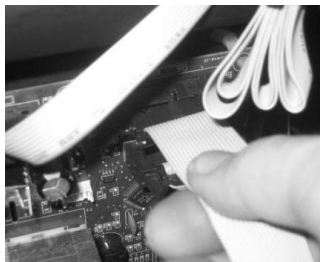

h)

Figure 22 – Installing the chronothermostat

17. Maintenance

17.1. Daily Maintenance

The Solzaima compact pellet requires careful maintenance. The main care to be taken is to regularly clean the ash in the pellet firing zone. This can be done in a practical way with the aid of a simple ash vacuum cleaner. The cleaning operation must be carried out after each firing of approximately 30 kg of pellets for the Compacta Eco 12 and 72 kg for the Compacta Eco 18 and 24.

Note: However, before carrying out any cleaning operation it is imperative that the compact is switched off and sufficiently cool to avoid accidents.



Figure 23 - Label with maintenance tasks



Figure 24 - Label with maintenance tasks

17.2. Weekly maintenance

- **Compacta Eco 12**

To perform this maintenance on the compact, the air passage tubes must be cleaned. To do so, lift the lid on the upper part of the compact (Figure 25-a) and then turn (Figure 25-b) and lift several times the handles there, in order to provoke the fall of the dirt accumulated inside the tubes.

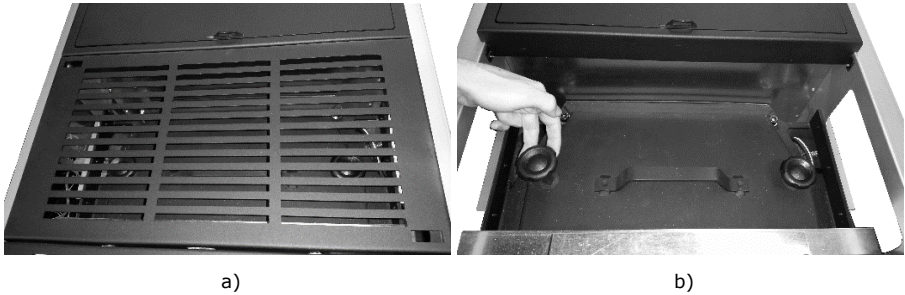

Figure 25 - Cleaning the turbulators

Then the inside of the compact must be cleaned by scrubbing with a steel brush the surfaces with accumulated dirt (Figure 26).



Figure 26 - Cleaning the inside of the water compact

Then the burner basket (Figure 27-a) and the ash basket (Figure 27-b) should be removed and the ash from both should be vacuumed. It is also necessary to clean the inside of the compact by opening the trap door. Finally, assemble the parts in the reverse order in which they were removed and close the appliance door.

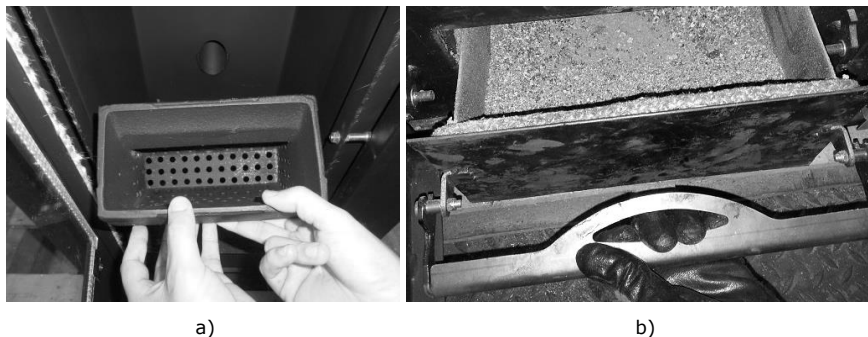

Figure 27 - a) Burning basket; b) Ash basket

⚠ WARNING! The frequency of maintenance tasks depends on the quality of the pellets.

- **Compacta Eco 18 e 24**

To perform this maintenance on the compact, the air passage tubes must be cleaned. To do so, lift the cover on the upper part of the compact (Figure 28-a) and then turn and lift several times the knobs (Figure 28-b), in order to provoke the fall of the dirt accumulated inside the tubes.

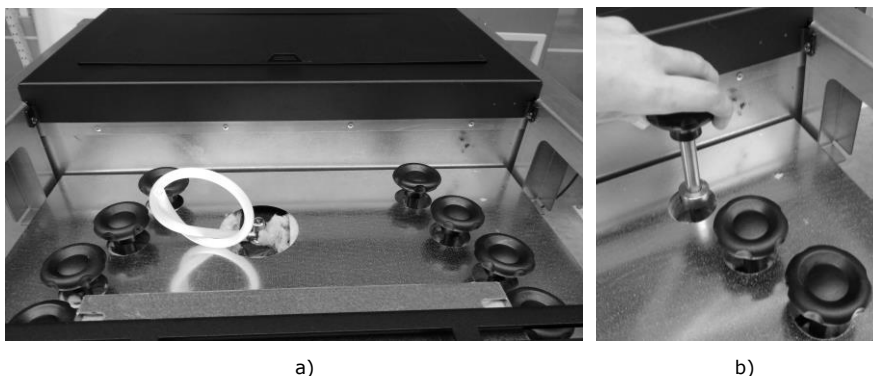

Figure 28 - Cleaning the turbulators

Then the inside of the compact must be cleaned by scrubbing the surfaces with an accumulated dirt with a steel brush (Figure 29).



Figure 29 - Cleaning the inside of the water compact

Then the burning basket (Figure 30-a) and the ash basket (Figure 30-b) should be removed and the ash from both should be vacuumed. It is also necessary to clean the inside of the compact by opening the trap door, as shown in Figure 32. Finally, assemble the parts in the reverse order in which they were removed and close the door of the appliance.



a)



b)

Figure 30 - a) Burning basket; b) Ash basket



Figure 31 - Firing basket cleaning

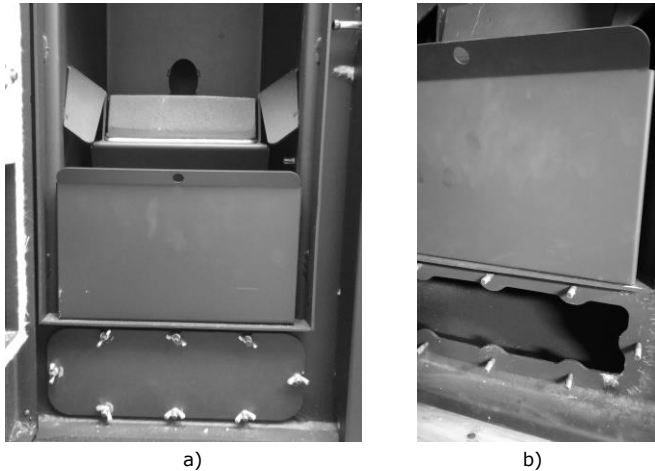

Figure 32 - Cleaning the inside of the compact

⚠ WARNING! The frequency of maintenance tasks depends on the quality of the pellets.

17.3. Additional cleaning

For every 600-800 kg of pellets consumed, an additional cleaning should be carried out.

In the water compact, the tubes through which the air circulates and the respective turbulators should be cleaned. To do this, open the cover located in the upper part of the equipment (Figure 33-a), remove the galvanized coating and remove the six wing nuts that fix each group of turbulators (Figure 33-b and c). Then pull the turbulators upward (Figure 33-d and e). A vacuum cleaner should be used to clean this area (Figure 33-f) and the inside of the tubes can be cleaned with a steel brush (Figure 33-g). The turbulators that have been removed should also be cleaned with a steel brush (Figure 33-h).

To put the turbulators back on, proceed in the opposite way to the figures.



a)

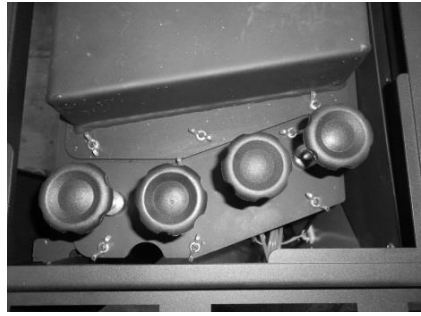

b)



c)



d)



e)



f)



g)

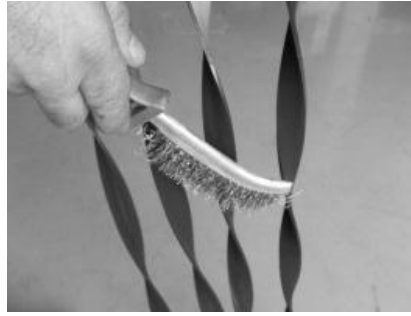

h)

Figure 33 - Cleaning of the air ducts and turbulators

In case you notice that the fume extraction is not being performed under the best conditions, we recommend cleaning the extractor as shown in Figure 34. However, we recommend this operation at least once a year.

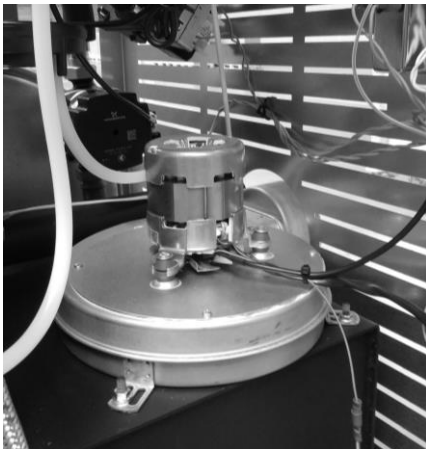

a)



b)

Figure 34 - a) Remove the screws; b) Remove the extractor

18. Maintenance plan and record

To ensure the proper operation of your compact it is essential to carry out the maintenance operations that are detailed in point 17 of the instruction manual or on the label with the maintenance and cleaning guide. There are tasks that must be done by an authorized technician. Contact the installer. In order not to lose the warranty on your appliance, you must perform all maintenance at the intervals indicated in the manual.

Customer Data:

Name:	
Address:	
Phone number:	
Model:	
Serial No:	

Company/SAT: _____		
Technical: _____		
Dates: _____		
Service hours of boiler: _____		
Quantity of pellets burned: _____		
Task	Check	Obs.
Clean burner and plate		
Clean smoke circuit and turbulators		
Vacuum pellet tank sawdust		
Check pressure of the expansion vessel		
Check safety valve 3 bar		
Check the fluid on the hydraulic circuit		
Clean the smoke extractor		
Check and clean the inspection T		
Clean chimney		
check the tightening of the screws		
Check engine cap pellet hopper		
_____ Signature/stamp		

Company/SAT: _____		
Technical: _____		
Dates: _____		
Service hours of boiler: _____		
Quantity of pellets burned: _____		
Task	Check	Obs.
Clean burner and plate		
Clean smoke circuit and turbulators		
Vacuum pellet tank sawdust		
Check pressure of the expansion vessel		
Check safety valve 3 bar		
Check the fluid on the hydraulic circuit		
Clean the smoke extractor		
Check and clean the inspection T		
Clean chimney		
check the tightening of the screws		
Check engine cap pellet hopper		
_____ Signature/stamp		

Company/SAT: _____		
Technical: _____		
Dates: _____		
Service hours of boiler: _____		
Quantity of pellets burned: _____		
Task	Check	Obs.
Clean burner and plate		
Clean smoke circuit and turbulators		
Vacuum pellet tank sawdust		
Check pressure of the expansion vessel		
Check safety valve 3 bar		
Check the fluid on the hydraulic circuit		
Clean the smoke extractor		
Check and clean the inspection T		
Clean chimney		
check the tightening of the screws		
Check engine cap pellet hopper		
_____ Signature/stamp		

Company/SAT: _____		
Technical: _____		
Dates: _____		
Service hours of boiler: _____		
Quantity of pellets burned: _____		
Task	Check	Obs.
Clean burner and plate		
Clean smoke circuit and turbulators		
Vacuum pellet tank sawdust		
Check pressure of the expansion vessel		
Check safety valve 3 bar		
Check the fluid on the hydraulic circuit		
Clean the smoke extractor		
Check and clean the inspection T		
Clean chimney		
check the tightening of the screws		
Check engine cap pellet hopper		
_____ Signature/stamp		

Company/SAT: _____		
Technical: _____		
Dates: _____		
Service hours of boiler: _____		
Quantity of pellets burned: _____		
Task	Check	Obs.
Clean burner and plate		
Clean smoke circuit and turbulators		
Vacuum pellet tank sawdust		
Check pressure of the expansion vessel		
Check safety valve 3 bar		
Check the fluid on the hydraulic circuit		
Clean the smoke extractor		
Check and clean the inspection T		
Clean chimney		
check the tightening of the screws		
Check engine cap pellet hopper		

Signature/stamp		

Company/SAT: _____		
Technical: _____		
Dates: _____		
Service hours of boiler: _____		
Quantity of pellets burned: _____		
Task	Check	Obs.
Clean burner and plate		
Clean smoke circuit and turbulators		
Vacuum pellet tank sawdust		
Check pressure of the expansion vessel		
Check safety valve 3 bar		
Check the fluid on the hydraulic circuit		
Clean the smoke extractor		
Check and clean the inspection T		
Clean chimney		
check the tightening of the screws		
Check engine cap pellet hopper		

Signature/stamp		

Company/SAT: _____		
Technical: _____		
Dates: _____		
Service hours of boiler: _____		
Quantity of pellets burned: _____		
Task	Check	Obs.
Clean burner and plate		
Clean smoke circuit and turbulators		
Vacuum pellet tank sawdust		
Check pressure of the expansion vessel		
Check safety valve 3 bar		
Check the fluid on the hydraulic circuit		
Clean the smoke extractor		
Check and clean the inspection T		
Clean chimney		
check the tightening of the screws		
Check engine cap pellet hopper		

Signature/stamp		

Company/SAT: _____		
Technical: _____		
Dates: _____		
Service hours of boiler: _____		
Quantity of pellets burned: _____		
Task	Check	Obs.
Clean burner and plate		
Clean smoke circuit and turbulators		
Vacuum pellet tank sawdust		
Check pressure of the expansion vessel		
Check safety valve 3 bar		
Check the fluid on the hydraulic circuit		
Clean the smoke extractor		
Check and clean the inspection T		
Clean chimney		
check the tightening of the screws		
Check engine cap pellet hopper		

Signature/stamp		

Company/SAT: _____		
Technical: _____		
Dates: _____		
Service hours of boiler: _____		
Quantity of pellets burned: _____		
Task	Check	Obs.
Clean burner and plate		
Clean smoke circuit and turbulators		
Vacuum pellet tank sawdust		
Check pressure of the expansion vessel		
Check safety valve 3 bar		
Check the fluid on the hydraulic circuit		
Clean the smoke extractor		
Check and clean the inspection T		
Clean chimney		
check the tightening of the screws		
Check engine cap pellet hopper		

Signature/stamp		

Company/SAT: _____		
Technical: _____		
Dates: _____		
Service hours of boiler: _____		
Quantity of pellets burned: _____		
Task	Check	Obs.
Clean burner and plate		
Clean smoke circuit and turbulators		
Vacuum pellet tank sawdust		
Check pressure of the expansion vessel		
Check safety valve 3 bar		
Check the fluid on the hydraulic circuit		
Clean the smoke extractor		
Check and clean the inspection T		
Clean chimney		
check the tightening of the screws		
Check engine cap pellet hopper		

Signature/stamp		

Company/SAT: _____		
Technical: _____		
Dates: _____		
Service hours of boiler: _____		
Quantity of pellets burned: _____		
Task	Check	Obs.
Clean burner and plate		
Clean smoke circuit and turbulators		
Vacuum pellet tank sawdust		
Check pressure of the expansion vessel		
Check safety valve 3 bar		
Check the fluid on the hydraulic circuit		
Clean the smoke extractor		
Check and clean the inspection T		
Clean chimney		
check the tightening of the screws		
Check engine cap pellet hopper		

Signature/stamp		

Company/SAT: _____		
Technical: _____		
Dates: _____		
Service hours of boiler: _____		
Quantity of pellets burned: _____		
Task	Check	Obs.
Clean burner and plate		
Clean smoke circuit and turbulators		
Vacuum pellet tank sawdust		
Check pressure of the expansion vessel		
Check safety valve 3 bar		
Check the fluid on the hydraulic circuit		
Clean the smoke extractor		
Check and clean the inspection T		
Clean chimney		
check the tightening of the screws		
Check engine cap pellet hopper		

Signature/stamp		

Company/SAT: _____		
Technical: _____		
Dates: _____		
Service hours of boiler: _____		
Quantity of pellets burned: _____		
Task	Check	Obs.
Clean burner and plate		
Clean smoke circuit and turbulators		
Vacuum pellet tank sawdust		
Check pressure of the expansion vessel		
Check safety valve 3 bar		
Check the fluid on the hydraulic circuit		
Clean the smoke extractor		
Check and clean the inspection T		
Clean chimney		
check the tightening of the screws		
Check engine cap pellet hopper		
Signature/stamp		

Company/SAT: _____		
Technical: _____		
Dates: _____		
Service hours of boiler: _____		
Quantity of pellets burned: _____		
Task	Check	Obs.
Clean burner and plate		
Clean smoke circuit and turbulators		
Vacuum pellet tank sawdust		
Check pressure of the expansion vessel		
Check safety valve 3 bar		
Check the fluid on the hydraulic circuit		
Clean the smoke extractor		
Check and clean the inspection T		
Clean chimney		
check the tightening of the screws		
Check engine cap pellet hopper		
Signature/stamp		

Company/SAT: _____		
Technical: _____		
Dates: _____		
Service hours of boiler: _____		
Quantity of pellets burned: _____		
Task	Check	Obs.
Clean burner and plate		
Clean smoke circuit and turbulators		
Vacuum pellet tank sawdust		
Check pressure of the expansion vessel		
Check safety valve 3 bar		
Check the fluid on the hydraulic circuit		
Clean the smoke extractor		
Check and clean the inspection T		
Clean chimney		
check the tightening of the screws		
Check engine cap pellet hopper		
Signature/stamp		

Company/SAT: _____		
Technical: _____		
Dates: _____		
Service hours of boiler: _____		
Quantity of pellets burned: _____		
Task	Check	Obs.
Clean burner and plate		
Clean smoke circuit and turbulators		
Vacuum pellet tank sawdust		
Check pressure of the expansion vessel		
Check safety valve 3 bar		
Check the fluid on the hydraulic circuit		
Clean the smoke extractor		
Check and clean the inspection T		
Clean chimney		
check the tightening of the screws		
Check engine cap pellet hopper		
Signature/stamp		

Company/SAT: _____		
Technical: _____		
Dates: _____		
Service hours of boiler: _____		
Quantity of pellets burned: _____		
Task	Check	Obs.
Clean burner and plate		
Clean smoke circuit and turbulators		
Vacuum pellet tank sawdust		
Check pressure of the expansion vessel		
Check safety valve 3 bar		
Check the fluid on the hydraulic circuit		
Clean the smoke extractor		
Check and clean the inspection T		
Clean chimney		
check the tightening of the screws		
Check engine cap pellet hopper		
Signature/stamp		

Company/SAT: _____		
Technical: _____		
Dates: _____		
Service hours of boiler: _____		
Quantity of pellets burned: _____		
Task	Check	Obs.
Clean burner and plate		
Clean smoke circuit and turbulators		
Vacuum pellet tank sawdust		
Check pressure of the expansion vessel		
Check safety valve 3 bar		
Check the fluid on the hydraulic circuit		
Clean the smoke extractor		
Check and clean the inspection T		
Clean chimney		
check the tightening of the screws		
Check engine cap pellet hopper		
Signature/stamp		

Company/SAT: _____		
Technical: _____		
Dates: _____		
Service hours of boiler: _____		
Quantity of pellets burned: _____		
Task	Check	Obs.
Clean burner and plate		
Clean smoke circuit and turbulators		
Vacuum pellet tank sawdust		
Check pressure of the expansion vessel		
Check safety valve 3 bar		
Check the fluid on the hydraulic circuit		
Clean the smoke extractor		
Check and clean the inspection T		
Clean chimney		
check the tightening of the screws		
Check engine cap pellet hopper		
Signature/stamp		

Company/SAT: _____		
Technical: _____		
Dates: _____		
Service hours of boiler: _____		
Quantity of pellets burned: _____		
Task	Check	Obs.
Clean burner and plate		
Clean smoke circuit and turbulators		
Vacuum pellet tank sawdust		
Check pressure of the expansion vessel		
Check safety valve 3 bar		
Check the fluid on the hydraulic circuit		
Clean the smoke extractor		
Check and clean the inspection T		
Clean chimney		
check the tightening of the screws		
Check engine cap pellet hopper		
Signature/stamp		

Company/SAT: _____		
Technical: _____		
Dates: _____		
Service hours of boiler: _____		
Quantity of pellets burned: _____		
Task	Check	Obs.
Clean burner and plate		
Clean smoke circuit and turbulators		
Vacuum pellet tank sawdust		
Check pressure of the expansion vessel		
Check safety valve 3 bar		
Check the fluid on the hydraulic circuit		
Clean the smoke extractor		
Check and clean the inspection T		
Clean chimney		
check the tightening of the screws		
Check engine cap pellet hopper		

Signature/stamp		

Company/SAT: _____		
Technical: _____		
Dates: _____		
Service hours of boiler: _____		
Quantity of pellets burned: _____		
Task	Check	Obs.
Clean burner and plate		
Clean smoke circuit and turbulators		
Vacuum pellet tank sawdust		
Check pressure of the expansion vessel		
Check safety valve 3 bar		
Check the fluid on the hydraulic circuit		
Clean the smoke extractor		
Check and clean the inspection T		
Clean chimney		
check the tightening of the screws		
Check engine cap pellet hopper		

Signature/stamp		

Company/SAT: _____		
Technical: _____		
Dates: _____		
Service hours of boiler: _____		
Quantity of pellets burned: _____		
Task	Check	Obs.
Clean burner and plate		
Clean smoke circuit and turbulators		
Vacuum pellet tank sawdust		
Check pressure of the expansion vessel		
Check safety valve 3 bar		
Check the fluid on the hydraulic circuit		
Clean the smoke extractor		
Check and clean the inspection T		
Clean chimney		
check the tightening of the screws		
Check engine cap pellet hopper		

Signature/stamp		

Company/SAT: _____		
Technical: _____		
Dates: _____		
Service hours of boiler: _____		
Quantity of pellets burned: _____		
Task	Check	Obs.
Clean burner and plate		
Clean smoke circuit and turbulators		
Vacuum pellet tank sawdust		
Check pressure of the expansion vessel		
Check safety valve 3 bar		
Check the fluid on the hydraulic circuit		
Clean the smoke extractor		
Check and clean the inspection T		
Clean chimney		
check the tightening of the screws		
Check engine cap pellet hopper		









Signature/stamp		

19. Maintenance guide label

ATTENTION

WELCOME TO YOUR BOILER - COMPACT / AUTOMATIC

This is a quick start guide. You will find further information in the instruction manual. This guide does not replace the careful reading of the instruction manual.

- 1  **MANUAL**
Read the instruction manual carefully from the first page.
- 2  **PELLETS***
It is important to use the correct pellets. For more information, see the instruction manual standard EN 15691-2.
- 3  **START (STOP)**
To start the boiler, press the STOP button for 3 seconds.
- 4  **ADVANCED**
For advanced settings, see the instruction manual.
- 5  **ALARM**
Any alarm appears on the display. Read the instruction manual for the shutdown of the equipment.
- 6  **LIST OF ALARMS**
You can use the list of alarms in the instruction manual.
- 7  **ALARM* RESET**
With the flashing alarm, press the ALARM* RESET button for 10 seconds until you hear the buzzer.
- 8  **CLEANING**
Please follow the cleaning instructions in the cleaning guide.

MAINTENANCE AND CLEANING GUIDE

Some of the tasks can be done by yourself and others by a technician*.

USER	TECHNICIAN	BOILER	DAILY**	WEEKLY**	300 kg**	500 kg**	1000 kg**	ANNUAL
Clean burner and clean glass on AUTO	<input type="checkbox"/>	<input type="checkbox"/>	<input type="checkbox"/>	<input type="checkbox"/>	<input type="checkbox"/>	<input type="checkbox"/>	<input type="checkbox"/>	<input type="checkbox"/>
Pull lubricator levers	<input type="checkbox"/>	<input type="checkbox"/>	<input type="checkbox"/>	<input type="checkbox"/>	<input type="checkbox"/>	<input type="checkbox"/>	<input type="checkbox"/>	<input type="checkbox"/>
Clean the hatch compartment	<input type="checkbox"/>	<input type="checkbox"/>	<input type="checkbox"/>	<input type="checkbox"/>	<input type="checkbox"/>	<input type="checkbox"/>	<input type="checkbox"/>	<input type="checkbox"/>
Clean ash container	<input type="checkbox"/>	<input type="checkbox"/>	<input type="checkbox"/>	<input type="checkbox"/>	<input type="checkbox"/>	<input type="checkbox"/>	<input type="checkbox"/>	<input type="checkbox"/>
Clean smoke circuit and turn flaps	<input type="checkbox"/>	<input type="checkbox"/>	<input type="checkbox"/>	<input type="checkbox"/>	<input type="checkbox"/>	<input type="checkbox"/>	<input type="checkbox"/>	<input type="checkbox"/>
Vacuum pellet tank several	<input type="checkbox"/>	<input type="checkbox"/>	<input type="checkbox"/>	<input type="checkbox"/>	<input type="checkbox"/>	<input type="checkbox"/>	<input type="checkbox"/>	<input type="checkbox"/>
Check pressure of the expansion vessel	<input type="checkbox"/>	<input type="checkbox"/>	<input type="checkbox"/>	<input type="checkbox"/>	<input type="checkbox"/>	<input type="checkbox"/>	<input type="checkbox"/>	<input type="checkbox"/>
Check safety valve 3 bar	<input type="checkbox"/>	<input type="checkbox"/>	<input type="checkbox"/>	<input type="checkbox"/>	<input type="checkbox"/>	<input type="checkbox"/>	<input type="checkbox"/>	<input type="checkbox"/>
Check the fluid on the hydraulic circuit	<input type="checkbox"/>	<input type="checkbox"/>	<input type="checkbox"/>	<input type="checkbox"/>	<input type="checkbox"/>	<input type="checkbox"/>	<input type="checkbox"/>	<input type="checkbox"/>
Clean the smoke extractor	<input type="checkbox"/>	<input type="checkbox"/>	<input type="checkbox"/>	<input type="checkbox"/>	<input type="checkbox"/>	<input type="checkbox"/>	<input type="checkbox"/>	<input type="checkbox"/>
Check and clean the inspection T	<input type="checkbox"/>	<input type="checkbox"/>	<input type="checkbox"/>	<input type="checkbox"/>	<input type="checkbox"/>	<input type="checkbox"/>	<input type="checkbox"/>	<input type="checkbox"/>
Clean chimney	<input type="checkbox"/>	<input type="checkbox"/>	<input type="checkbox"/>	<input type="checkbox"/>	<input type="checkbox"/>	<input type="checkbox"/>	<input type="checkbox"/>	<input type="checkbox"/>

* Always call a technician. ** Dependent on the fuel or oil. *** 1 year or 1000 kg or 2000 kg of pellets to use. **** To perform the operation. ***** For the maintenance operation, contact your installer.

Figure 35 - Maintenance label

Note: The safety warnings sticker label is attached from factory to the unit's pellet lid, in the Portuguese language. Attached to the manual you will find other language versions of the sticker labels (Spanish, English, French and Italian). If necessary, remove the Portuguese language label and replace it with the label in your country's language.

20. Installation Schemes

Simple connection to central heating radiators only

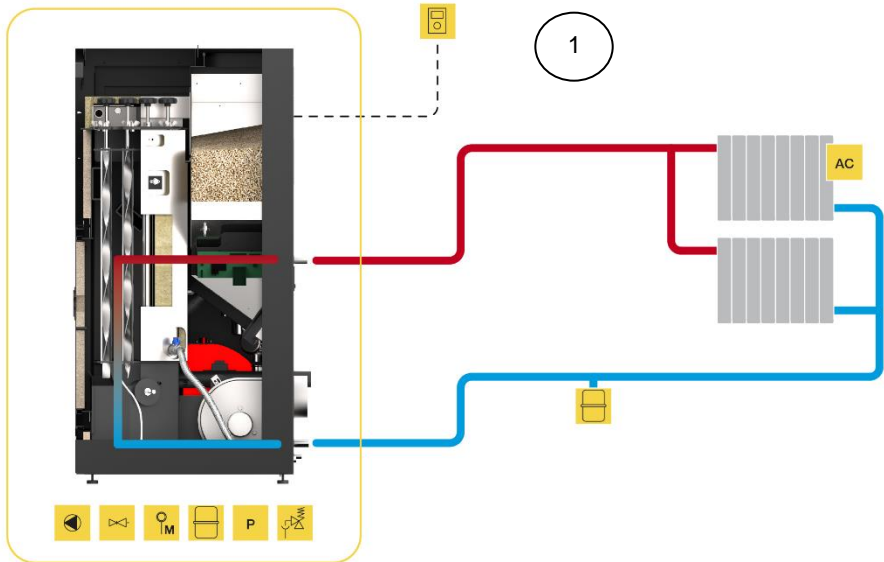

Figure 36 - Simple connection to central heating radiators only

Notes:

- O cronotermostato deve ter 1º a 2 ºC de hysteresis. (1)
- Hidro independente "On" (regulação controlada da temperatura da água)
- Bomba moduladora "On" (ligada)
- Inibição de detecção de água "On"
- Hidro-limpeza alternativa "On" (ligado)
- Bomba "On"= 50 ºC
- Bomba "Off"= 50 ºC

We can adjust/change according to the customer's criteria to another temperature.

Connection to central heating radiators and sanitary water combined with solar panel

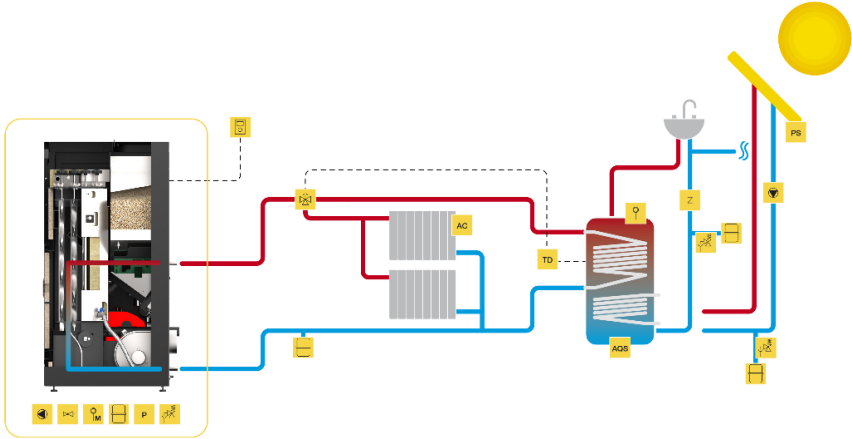

Figure 37 - Connection to central heating radiators and sanitary water combined with solar panel

Example of the electrical connection of a chronothermostat (room air control), a differential thermostat connected to the DHW tank, and the three-way valve to a relay box.

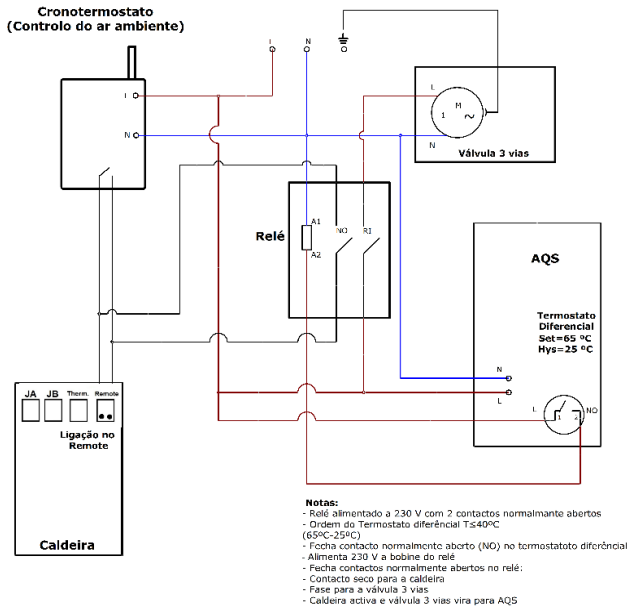

Figure 38 - Electrical connection of a chrono-thermostat (room air control), a differential thermostat connected to the DHW tank, and the three-way valve to a relay box

Connection to central heating radiators, combined with another backup compact and sanitary water combined with solar panel

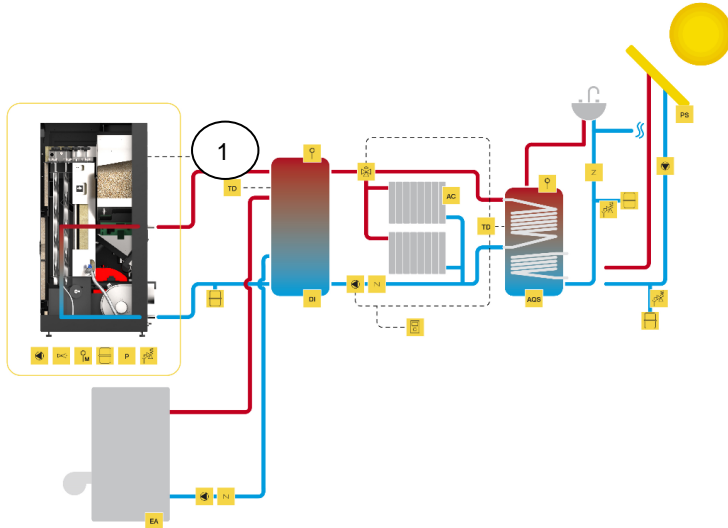

Figure 39 - Connection to central heating radiators, cojugated with another backup compact and sanitary water combined with solar panel

Notes:

- The differential thermostat must have a hysteresis of 15 to 25°C. (1)
 - Independent Hydro "Off" (water temperature controlled regulation), put the compact in "manual" mode and power level at "5".
 - Modulating pump "On"
 - Water sensing inhibition "On"
 - Alternative hydro shutdown "On"
 - Pump "On" = 50 °C
 - Pump "Off" = Same temperature as thermostat or 1 °C below differential thermostat temperature
- No caso de utilizar a caldeira com termostato diferencial a máquina deve estar conetada na conexão "Remote".

Calculating Inertia Deposits: for compact pellets it is recommended that the inertia tank is 20l/kW.

NOTE: For Columbus electronics when connecting the stove to the inertia tank it is necessary to change the following parameters:

P77=04

A01=04

(if necessary contact technical support)

Connection to underfloor heating, combined with another backup compact and sanitary water combined with solar panel

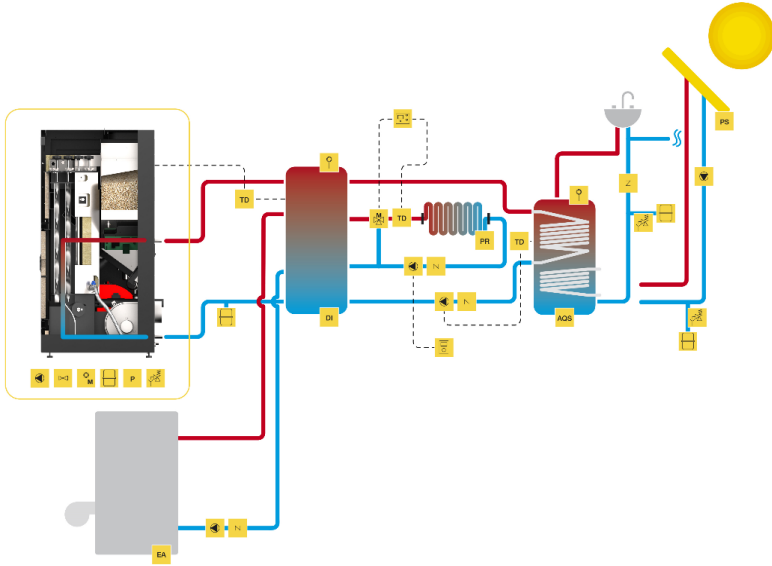

Figure 40 - Connection to underfloor heating, cojugated with another backup compact and sanitary water combined with solar panel

NOTE: For Columbus electronics when connecting the stove to the inertia tank it is necessary to change the following parameters:

P77=04

A01=04

(if necessary contact technical support)

Symbology

EA	Fuel backup equipment (gas, diesel)	Z	Non-return valve		3-way motorised valve	M	Mixing valve		Ambient thermostat
DI	Inertia deposit		Circulating pump		Automatic air vent		Anti-condensation valve		Hot water
AQS	Sanitary hot waters	P	Pressure sensor		Manual air vent		Thermal security valve		Cold water
PS	Solar panel	TD	Differential thermostat		Closed expansion vessel		Security pressure valve		Electrical connections
AC	Central heating	PR	Radiant heated floor		Drain valve		Underfloor heating controller		

Figure 41 - Symbology

21. Electrical Diagram of the Compact unit

21.1. Electrical Diagram – not applicable to Columbus Electronics

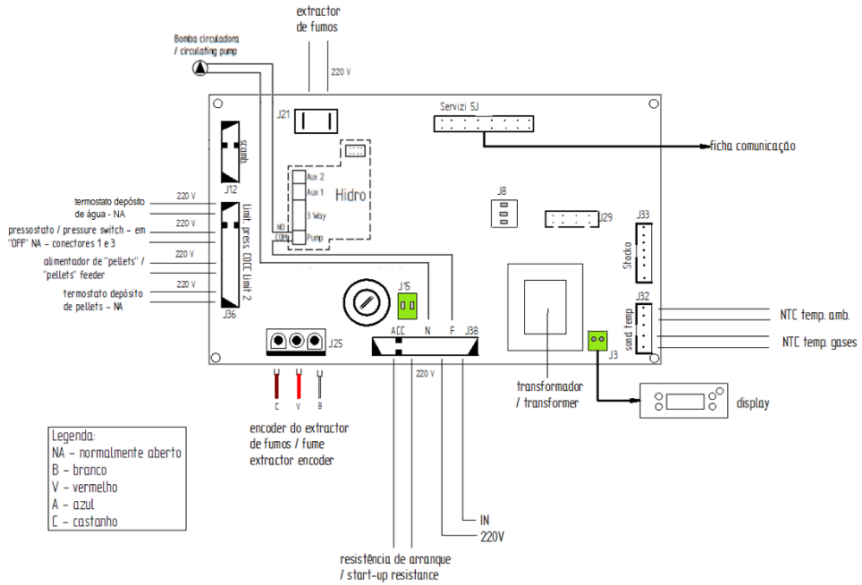

Figure 42 - Compacta Eco 12 Electrical Diagram

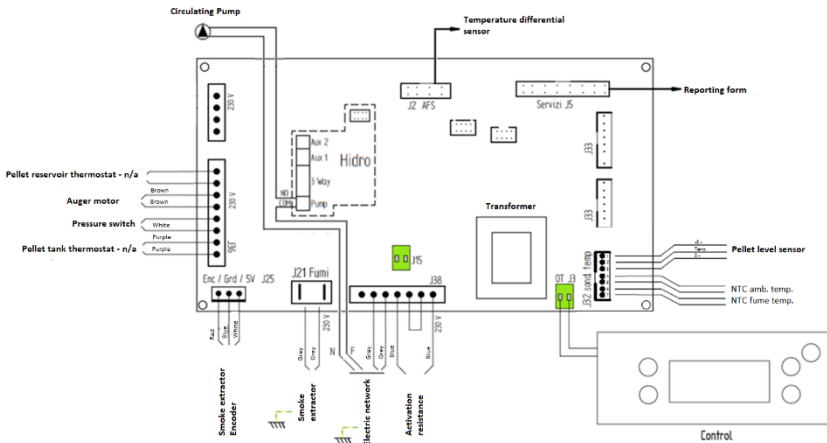

Figure 43 - Compacta Eco 18 and 24 Electrical Diagram

21.2. Electrical Diagram – Applicable to Columbus Electronics

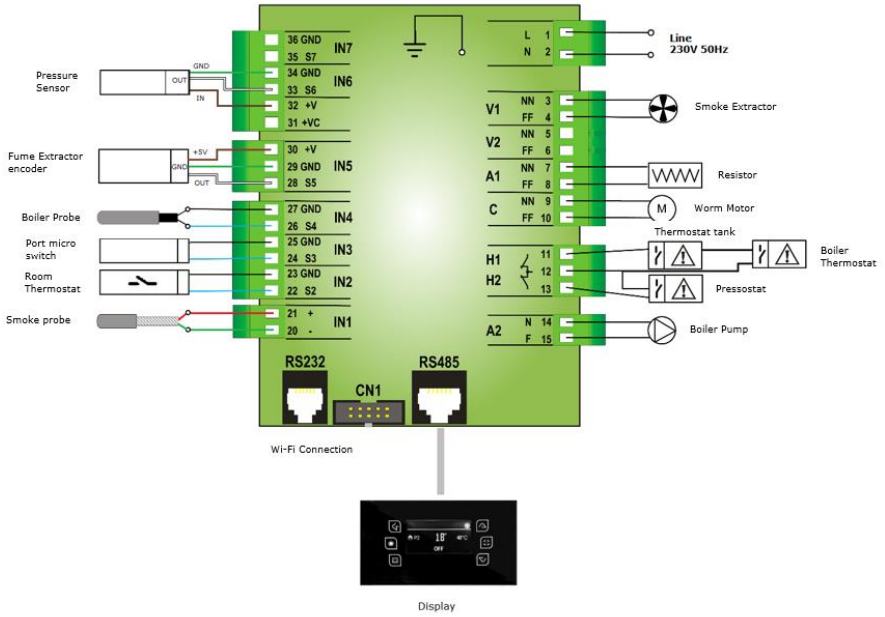

Figure 44 - Electrical schematic (Columbus electronics)

22. Hydraulic Pumps

22.1. Pump UPM3 with Hybrid 15-70 130 mm

Performance graph for the circulating pump

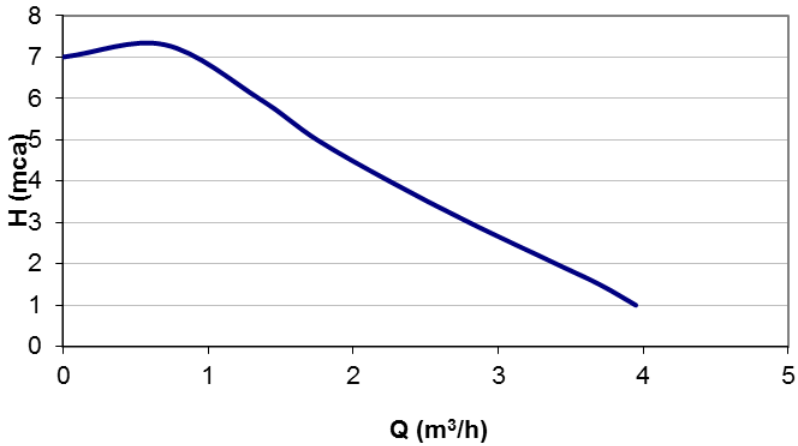

Figure 45 – Circulating pump performance graph

User interface

The user interface was designed with a single button, a red/green LED and four yellow LEDs.

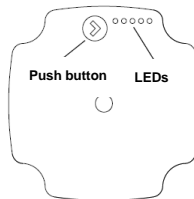

Figure 46 – User interface

When the pump is operating, the LED 1 is green. 4 yellow LEDs indicate the current performance of the pump, as shown in the following table.

Active LED	Performance (%)
LED Green	0 (Standby)
LED Green + 1 LED Yellow	0 - 25
LED Green + 2 LED Yellow	25 - 50
LED Green + 3 LED Yellow	50 - 75
LED Green + 4 LED Yellow	75 - 100

Table 5 - Performance of the pump

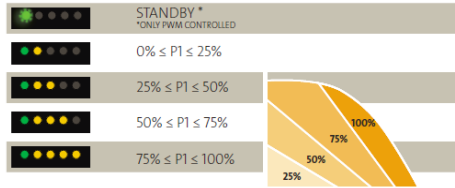

Figure 47 – Performance of the pump

Note: the pump is configured as standard at full capacity (75-100%).

Changing the setting of the pump

Can be chosen between the view of the performance of pump and the view of settings, just press the button once.

If you need to change the pump performance, you must press the button for 2 seconds (see Figure 48), after this action the LEDs start blinking, then you must press the button until the desired setting (see Table 6), after 10 seconds the display automatically switches to the view of performance with alteration saved.

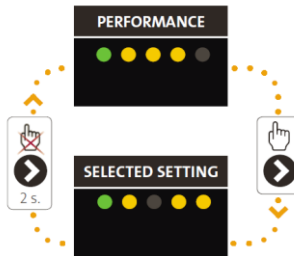

Figure 48 – Pump settings

Maximum manometric height (m)	Configuration
2-4	
3-5	
4-6	
5-7	

Table 6 - Pump settings

Alarms

If the pump detects one or more errors, the LED 1 changes from green to red when the alarm is activated the yellow LED indicates the type of alarm (see Table 6), if we have several alarms at the same time, the yellow LED indicates the alarm with higher priority, the priority sequence is defined on table as follows:



Display	Priority	Alarm	Action
LED 1 red + LED 5 yellow 	1	Rotor is blocked	Wait or deblock the shaft
LED 1 red + LED 4 yellow 	2	Supply voltage too low	Control the supply voltage
LED 1 red + LED 3 yellow 	3	Electrical error	Control the supply voltage or replace the pump

Table 7 – Alarms

22.2. Bomba Wilo 15-130/7-50

A The Wilo 15-130/7 50 circulator pump consists of:

1. Pump housing with threaded connections
2. Wet rotor motor
3. Outlet labyrinths (4x all around)
4. Body screws
5. Control module
6. Nameplate
7. Control key for pump regulation
8. LED operation/malfunction indicator
9. Indication of selected control mode
10. Indication of selected characteristic curve (I, II or III)

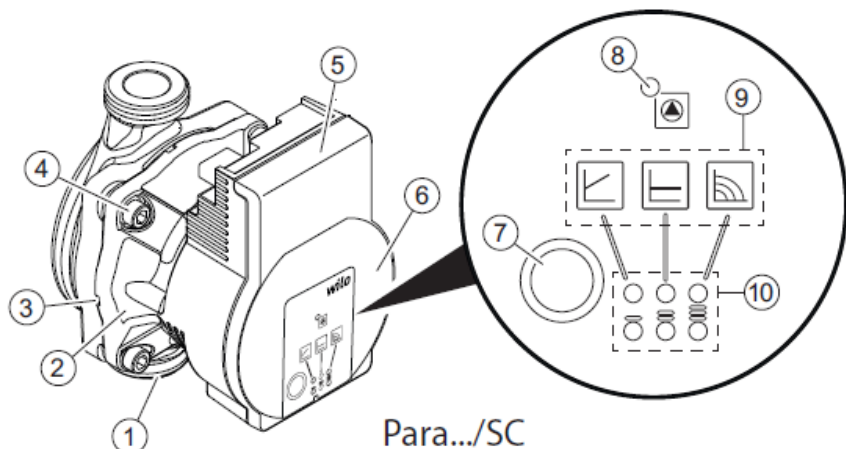

Para.../SC

Figure 49 - Pump Wilo

Install the pump

During installation the following must be observed, Figure 50:

- Pay attention to the direction arrow on the pump body (1).
- Install mechanically tension-free, with wet rotor motor located horizontally (2).
- Place mechanical seals on the threaded connections.
- Screw in the threaded connections.
- Secure the pump against twisting with a wrench and screw it firmly into the pipes.
- If necessary, reinsulate the thermal insulation.

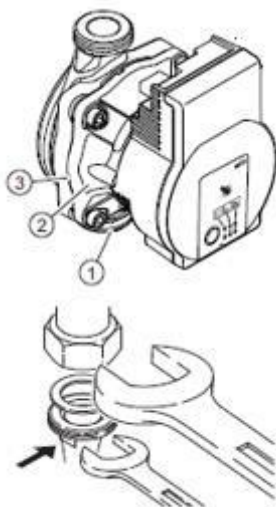

Figure 50 - Pump installation

CAUTION!

- Lack of heat dissipation and condensation water can damage the control module and the wet rotor motor.
- Do not insulate the glandless motor (2).
- Leave all condensate drain openings (3) open.

Indicator lights

The user interface is designed with the following LED indicators and control keys.



Active LED	Description
	<ul style="list-style-type: none"> - LED is lit up in green in normal operation. - LED lights up/flashes in case of a fault.
	<ul style="list-style-type: none"> - Display of selected control mode ΔP-v, ΔP-c and constant speed (the only mode available in Solzaima electronics).
	<ul style="list-style-type: none"> - Display of selected pump curve (I, II, III) within the control mode.
	<ul style="list-style-type: none"> - LED indicator combinations during the pump venting function, manual restart and key lock.

Table 8 - Indicator lights

Operating button

Press

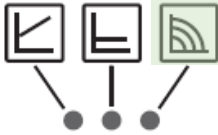
- Select control mode.
- Select pump curve (I, II e III - Figure 55) within the control mode.

Press and hold

- Activate the pump venting function (press for 3 seconds).
- Activate manual restart (press for 5 seconds).
- Lock/unlock button (press for 8 seconds).

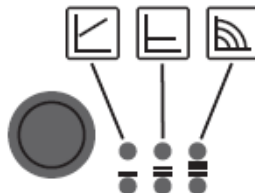

Figure 51 - Operating button

Setting the control mode

Select control mode

The LED selection of control modes and corresponding pump curves takes place in clockwise succession.

Press the operating button briefly (approx. 1 second). LEDs display the set control mode and pump curve.

In the Solzaima's electronics, it is only possible to select the **green** diagram corresponding to constant speed, but 3 different speeds can be chosen.

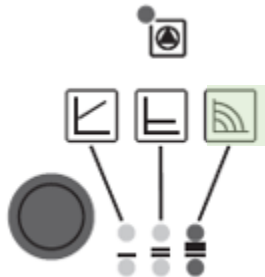

Figure 52 - Control mode

LED display	Control mode	Pump curve
	Constant speed.	I
	Constant speed.	II
	Constant speed.	III

Table 9 - Control mode

Functions

Venting

If the pump does not vent automatically:

- Activate the pump venting function via the operating button, press and hold for 3 seconds, then release.
- The pump venting function is initiated and lasts 10 minutes.
- The top and bottom LED rows flash in turn at 1 second intervals.
- To cancel, press and hold the operating button for 3 seconds.

Manual restart

The pump attempts an automatic restart upon detecting a blockage.

If the pump does not restart automatically:

- Activate manual restart via the operating button: press and hold for 5 seconds, then release.
- The restart function is initiated, and lasts max. 10 minutes.
- The LEDs flash in succession clockwise.
- To cancel, press and hold the operating button for 5 seconds.



Figure 53 - Manual restart

⚠ WARNING! After the restart, the LED display shows the previously set values of the pump.

Lock/unlock the button

- To activate the key lock, press and hold the operating button for 8 seconds until the LEDs for the selected setting briefly flash, then release.
- LEDs flash constantly at 1-second intervals.
- The key lock is activated: pump settings can no longer be changed.
- The key lock is deactivated in the same manner as it is activated.



Figure 54 - Lock/unlock the button

Activating factory setting

- The factory setting is activated by pressing and holding the operating button whilst switching off the pump.
- Press and hold the operating button for at least 4 seconds.
- All LEDs flash for 1 second.
- The LEDs for the last setting flash for 1 second.
- When the pump is switched on again, the pump runs using the factory settings (delivery condition).

Faults, Causes and Solutions

The following tables show some of the problems of installing Wilo pumps.

Faults	Causes	Solutions
Pump is not running although the power supply is switched on	No voltage supply at pump	Rectify the power interruption
Noisy pump	Cavitation due to insufficient suction pressure	Increase the system pressure within the permissible range Check the delivery head and set it to a lower head if necessary
Building does not warm up	Thermal output of the heating surfaces is too low	Increase setpoint

Table 10 - List of faults and solutions



LED	Faults	Causes	Solutions
Lights up red 	Blocking	Rotor blocked	Activate manual restart or contact customer service
	Contacting/winding	Winding defective	
Flashes red 	Under/overvoltage	Power supply too low/high on mains side	Check mains voltage and operating conditions, and request customer service
	Excessive module temperature	Module interior too warm	
	Short-circuit	Motor current too high	
Flashes red/green 	Generator operation	Water is flowing through the pump hydraulics, but there is no mains voltage at the pump	Check the mains voltage, water quantity/pressure and the ambient conditions
	Dry run	Air in the pump	
	Overload	Sluggish motor, pump is operated outside of its specifications (e.g., high module temperature). The speed is lower than during normal operation.	

Table 11 - List of faults and solutions

Reading performance curve

For a given speed, the pump can overcome a given pressure drop, for a given flow:

- The pressure drop (or manometric height) is identified on the ordinate axis, with the units in metres (m) - It depends on the installation.
- The flow rate is identified on the x-axis, with the units in cubic metres per hour (m^3/h) - Depends on the power to be conditioned.
- Constant velocity curves are present in the graph, identified in I, II and III.
- The installer must set the required curve from the lowest to the highest speed by means of the required flow rate and the head loss of the installation.
- The pumps run at the highest speed in the factory.

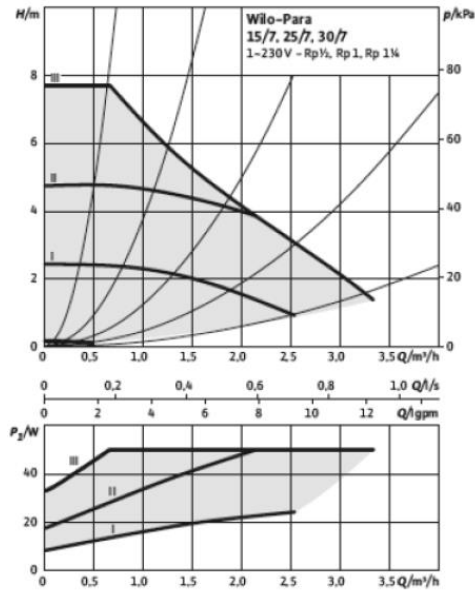

Figure 55 - Pump performance - Constant speeds I, II and III

23. End of life of a compact pellet

Approximately 90% of the materials used to manufacture these units are recyclable, contributing towards a reduced environmental impact and a more sustainable planet. End-of-life units should be processed by licensed waste operators. We recommend contacting your local council to ensure the unit is collected and handled pursuant to any legal requirements.

24. Sustainability

Solzaima designs and manufactures biomass solutions and biomass-fuelled equipment as a primary energy source. This is our contribution for the sustainability of our planet – an economically viable and environmentally-friendly alternative, following environmental best management practices to ensure an efficient carbon cycle management.

Solzaima makes all efforts to learn and to know the national forest park while efficiently responding to energy demands, taking permanent care to maintain its biodiversity and natural wealth that are essential for the quality of life on our planet.

SOLZAIMA is a member of the Portuguese **Sociedade Ponto Verde**, which manages packaging waste from products that the company places on the market, so you can take the packaging waste from your unit, such as plastic and cardboard, to your nearest recycling point.

SOLZAIMA is a member of **Amb3E**, the entity responsible for collecting waste electrical and electronic equipment (WEEE). Thus, end-of-life units with forced ventilation systems should be transported to an appropriate WEEE-processing location. When you disassemble your equipment, you can take its electrical components to your nearest WEEE collection point.



25. Glossary

Ampere (A): unit of measurement (SI) of electric current intensity.

bar: unit of pressure and equals exactly 100,000 Pa. This pressure value is very close to that of standard atmospheric pressure.

* **cal (calorie):** equal to the amount of heat required to increase the temperature of one gram of water by one degree centigrade.

* **Groove:** housing for the sealing ring.

* **cm (centimetres):** unit of measurement.

* **CO (carbon monoxide):** Lightly flammable, colourless, odourless and very dangerous gas, due to its toxicity.

* **CO₂ (carbon dioxide):** Gas needed by plants on the one hand for photosynthesis, and emitted into the atmosphere on the other, contributing to the greenhouse effect.

* **Combustion:** a process that releases energy. Combustion is basically a chemical reaction that requires three things in order to take place: fuel, oxidant and ignition temperature.

* **Oxidant:** chemical substance that feeds combustion (essentially oxygen) and is essential for it to take place.

* **Fuel:** anything that can undergo combustion, in this case wood.

* **Creosote:** chemical compound created by combustion. This compound is sometimes deposited on the glass and flue of an insert fire.

* **Circuit breaker:** Electromechanical device that protects a given electrical appliance.

* **Energy Efficiency:** capacity to generate large quantities of heat with the least amount of energy possible, causing the least environmental impact and reducing the energy budget.

* **CO Emissions:** emission of carbon monoxide gas into the atmosphere.

* **CO Emissions (13% O₂):** carbon monoxide content corrected for 13% of O₂.

* **Differential Switch:** protects people and property against earthing failures, preventing electric shocks and fires.

* **kcal (Kilocalorie):** multiple unit of measurement of calories. Equivalent to 1000 calories.

* **kW (Kilowatt):** Unit of measurement equal to 1000 watts.

* **mm (millimetres):** unit of measurement.

* **mA (milliampere):** unit of measurement of electric current.

- * **Pa (Pascal):** standard SI unit of pressure and tension. This unit is named after Blaise Pascal, eminent French mathematician, physicist and philosopher.
- * **Calorific Value:** also known as specific combustion heat. Represents the quantity of heat released when a certain quantity of fuel is completely burned. Calorific value is expressed in calories (or kilocalories) per unit of weight of fuel.
- * **Rated output:** Electric power consumed by an energy source. Measured in watts.
- * **Nominal heat output:** heating capacity, e.g., the heat energy the unit transfers from energy present in the firewood – measured for a standard load of firewood over a given period of time.
- * **Power output:** a manufacturer's recommendation from tests on the equipment with firewood loads within a reasonable operating range. This power output range will present different firewood consumptions per hour.
- * **Plumb:** vertically above the installation.
- * **Efficiency:** expressed as a percentage of “useful energy” that can be extracted from a given system, taking into account the “total energy” of the fuel used.
- * **Ignition temperature:** temperature above which the fuel can enter into combustion.
- * **Heat-resistant:** resistant to high temperatures and thermal shock.
- * **Ceramic glass:** Highly resistant ceramic material produced through controlled crystallisation of vitreous materials. Used widely in industrial applications.
- * **W (Watt):** SI unit of power.

26. Warranty

1. Social name and address of the producer and Object

Solzaima, S.A.

Rua dos Outarelos, 111

3750-362 Belazaima do Chão

This document does not substantiate the provision by Solzaima S.A. of a voluntary warranty on its produced and marketed products (from now on mentioned as "Product (s)"), but rather a guide, intended to be enlightening for the effective activation of the legal warranty that benefits consumers (from now on mentioned as "Warranty"). This document does not affect the legal rights of warranty, emerging from the purchase agreement whose purpose is the Product(s).

2. Product identification on which rests the warranty

The activation of the warranty presupposes prior and correct identification of the product object towards Solzaima, SA, being promoted by providing the Product 's packing data indicated in the purchase invoice or in the product characteristics plate (model and serial number).

3. Product warranty terms

3.1 Solzaima, S.A., responds to the Buyer, for the lack of conformity of the Product with the respective contract of sale, within the following periods:

3.1.1 A period of 24 months from the date of delivery of the good, in the case of domestic use of the product, save the provisions of the following number regarding the intensive use;

3.1.2 A term of 6 months from the date of delivery of the goods, in the case of professional, or industrial, or intensive use of the products - Solzaima means by professional, industrial or intensive use of all products installed in industrial spaces, commercial, or whose use exceeds 1500 hours per calendar year;

3.2 A functional test of the product must be performed before finishing the installation (plaster, masonry, coatings, paintings, among others);

3.3 No equipment can be replaced after the 1st Burn without the express authorization of the producer;

3.4 Any product must be repaired on the site of installation without causing

serious inconvenience to the parties, save, if this proves impossible, or disproportionate;

3.5 In order to exercise its rights, and provided that the term indicated in 3.1 is not exceeded, the Buyer must report in writing to Solzaima, S.A., the lack of conformity of the Product within a maximum period of:

3.5.1 60 (sixty) days after the date on which it has detected it in the case of domestic use of the product;

3.5.2 Thirty (30) days from the date of its detection, in the case of professional use of the Product.

3.6 In the pellet range equipments, the commissioning service is required to activate the warranty. It must be registered up to 3 months after the date of invoice, or, 100 hours of work of the product (whichever occurs first);

3.7 During the Warranty period referred to in paragraph 3.1 (and for this to remain valid), repairs to the Product must be performed exclusively by the Official Technical Services of the Brand. All services provided under this Guarantee will be performed Monday through Friday within the working time and calendar legally established in each region.

3.8 All requests for assistance must be submitted to the Solzaima, S.A. Customer support service, by means of a proper form present on the Website www.solzaima.co.uk, or, e-mail: support.cliente@solzaima.pt. At the time of the technical assistance to the Product, the Buyer must present, as proof of the Product Warranty, the purchase invoice of the same or another document demonstrating its acquisition. In any case, the document proving the acquisition of the Product must contain the identification of the Product (as mentioned in point 2 above) and its date of acquisition. Alternatively, and in order to validate the Product Warranty, the PSR - document certifying the commissioning of the machine (when applicable)).

3.9 The Product will have to be installed by a qualified professional for the purpose, in accordance with the regulations in force in each geographical area, for the installation of these Products and complying with all the regulations in force, especially regarding chimneys, as well as other applicable regulations for aspects such as water supply, electricity and / or other related to the equipment or sector

and as described in the instruction manual.

A product installation that does not conform to the manufacturer's specifications and / or does not comply with the legal regulations on this subject will not give rise to the application of this Warranty. Whenever a product is installed outdoors, it must be protected against weather effects such as rain and wind. In these cases, it may be necessary to protect the appliance by means of a cabinet, or a properly ventilated protective case. Appliances should not be installed in places that contain chemicals in their atmosphere, in saline or high humidity environments, as mixing them with air may produce rapid corrosion in the combustion chamber. In this type of environment, it is especially recommended that the appliance be protected with anti-corrosion products for this purpose, especially during times of operation. As a suggestion it is indicated the application of graphite greases indicated for high temperatures with function of lubrication and anti-corrosion protection.

3.10 In equipment belonging to the pellet family, in addition to the daily and weekly maintenance contained in the instruction manual, it is also obligatory to carry out the cleaning inside and in the respective chimney for the evacuation of fumes. These tasks should be carried out every 600-800 kg of pellets consumed, in the case of stoves (air and water) and compact compacts, and every 2000-3000 kg of pellets consumed in the case of automatic compacts. In the event that these quantities are not consumed, at least one systematic preventive maintenance must be carried out annually.

3.11 It is the Buyer's responsibility to ensure that periodic maintenance is carried out, as indicated in the instruction and handling manuals accompanying the Product. Whenever requested, it must be proved by submitting the technical report of the entity responsible for it, or alternatively by registering them in the instruction manual in the dedicated section.

3.12 In order to avoid damage to the equipment caused by overpressure, safety elements such as pressure relief valves and / or thermal discharge valves, if applicable, as well as an expansion vessel fitted to the installation, shall be ensured at the time of installation and its correct functioning must be ensured . It should be noted that: the valves referenced must have a value equal to or less than the pressure supported by the equipment; there shall be no cut-off valve between the equipment and its safety valve; provision should be made for a systematic preventive maintenance plan to attest to the correct functioning of the said safety features; irrespective of the type of appliance, all safety valves shall be channelled

to drained sewage to prevent damage to the dwelling by water discharges. Product Warranty does not include damages caused by non-channeling of water discharged by said valve.

3.13 In order to avoid damage to the equipment and attached pipes by galvanic corrosion, it is advisable to use dielectric separators in the connection of the equipment to metal pipes whose characteristics of the materials applied to this type of corrosion. Product Warranty does not include damages caused by non-use of such dielectric separators.

3.14 The water or thermofluid used in the heating system (hydro stoves, compacts, central heating stoves, among others) must comply with the legal requirements in force, as well as guarantee the following physical and chemical characteristics: absence of solid particles in suspension; low level of conductivity; residual hardness of 5 to 7 degrees; neutral pH, close to 7; low concentration of chlorides and iron; and absence of air inlets by depression or others. In case the installation enhances automatic water make-up, it should consider upstream a preventive treatment system composed of filtration, decalcification and preventive dosing of polyphosphates (scale and corrosion), as well as a degassing step, if necessary. If in any circumstance any of these indicators show values that are not recommended, the Warranty will cease to have effect. It is also compulsory to place a non-return valve between the automatic filling valve and the mains water supply, and that said supply always has constant pressure, even with a lack of electricity, not depending on lift pumps, autoclaves, or others.

3.15 Except as expressly provided by law, a warranty intervention does not renew the warranty period of the Product. The rights arising from the Warranty are not transferable to the purchaser of the Product.

3.16 The equipment must be installed in accessible places and without risk to the technician. The means necessary for access to them shall be made available by the Buyer, and the Buyer shall be responsible for any charges arising therefrom.

3.17 The Warranty is valid for the Products and equipment sold by Solzaima SA solely and exclusively within the geographical and territorial zone of the country where the Product was sold by Solzaima.

4. Circumstances that exclude the application of the Warranty

Excluded from the Warranty, being the total cost of the repair borne by the Buyer, the following cases:

- 4.1. Products with more than 2000 operating hours;
- 4.2. Refurbished and resold products.
- 4.3. Maintenance operations, Product settings, commissioning, cleaning, elimination of errors or anomalies that are not related to deficiencies of equipment components and replacement of the batteries
- 4.4. Components in direct contact with fire such as: vermiculite supports, deflector or protective plates, vermiculite, sealing lanyards, burners, ash drawers, wood chips, smoke registers, ash grates, whose wear is directly related to the conditions of use. Degradation of the paint, as well as corrosion due to degradation of the paint, due to overloading of fuel, use of an open drawer or excessive drainage of the installation chimney (the chimney must respect the drawing recommended in the Product Technical Data Sheet). Glass breakage due to improper handling or other reason not related to Product deficiency. In the pellet family, the ignitors are aware part, so they are only guaranteed for 6 months, or 1000 ignitions (whichever comes first);
- 4.5. Wear considered components, such as bearings and bushes;
- 4.6. Deficiencies of components external to the Product that may affect its correct functioning, as well as material or other damages (e.g. tiles, roofing, waterproofing, pipes, or personal injury) caused by improper use of materials in the installation or by non-execution of the product installation in accordance with the rules for the installation, applicable regulations or rules of good art, in particular when the application of suitable piping to the temperature in use, expansion vessels, non-return valves, safety valves , anti-condensation valves, among others;
- 4.7. Products whose operation has been affected by failures or deficiencies of external components or by poor sizing;

4.8. Defects caused by the use of accessories or replacement components other than those determined by Solzaima, S.A.;

4.9. Defects arising from non-compliance with the installation, use and operation instructions or applications not conforming to the intended use of the Product, or from abnormal climatic factors, unusual operating conditions, overload or maintenance or cleaning performed improperly;

4.10. The Products that have been modified or manipulated by people outside the Official Technical Services of the brand and consequently without the explicit authorization of Solzaima, SA.;

4.11. Damage caused by external agents (rodents, birds, spiders, etc.), atmospheric and / or geological phenomena (earthquakes, storms, frost, hailstorms, thunderstorms, etc.), humid or saline aggressive environments such as proximity of the sea or river, as well as those derived from excessive water pressure, inadequate power supply (voltage with variations greater than 10%, with a nominal value of 230V, or, neutral voltage greater than 5V, or absence of earth protection); pressure or supply of inadequate circuits, acts of vandalism, urban confrontation and armed conflict of any kind, as well as derivatives;

4.12. Failure to use the fuel recommended by the manufacturer is a condition of exclusion from the Warranty.;

Explanatory note: In the case of pellet appliances the used fuel must be certified by EN 14961-2 grade A1. Also, before buying large quantity you should test the fuel to see how it behaves. In wood equipment, this moisture content must be of less than 20%.

4.13. The appearance of condensation, either by poor installation or by the use of non-virgin fuels (such as pallets or wood impregnated with paints or varnishes, salt or other components), which may contribute to the accelerated degradation of equipment and especially to your combustion chamber;

4.14. All Products, Components or damaged components in transportation or installation;

4.15. Cleaning operations carried out on the appliance or its components due to condensation, fuel quality, bad settings or other circumstances of the installation location. Also excluded from the Warranty are interventions for the descalsification of the Product (the removal of limestone or other materials deposited inside the apparatus and produced by the quality of the water supply). Also excluded from this warranty are air bleeding interventions of the circuit or unblocking of circulating pumps.

4.16. The installation of the equipment supplied by Solzaima, S.A. should contemplate the possibility of their easy removal, as well as points of access to the mechanical, hydraulic and electronic components of the equipment and the installation. When the installation does not allow immediate and safe access to the equipment, the additional cost of access and security will always be borne by the Buyer. The cost of disassembling and assembling boxes of plasterboard or masonry walls, insulation or other elements such as chimneys and hydraulic connections that prevent free access to the Product (if the Product is installed inside a carton of plasterboard , masonry or other dedicated space must comply with the dimensions and characteristics indicated in the instruction manual and use accompanying the appliance).

4.17. Interventions of information or clarification at home about the use of its heating system, programming and / or reprogramming of control and regulating elements, such as thermostats, regulators, programmers, etc.;

4.18. Interventions for the adjustment of fuel receipes in pellet devices, cleaning, detection of water leaks in pipes external to the apparatus, damage caused due to the need to clean the gas evacuation machinery or flues;

4.19. Urgency interventions not included in the provision of Warranty i.e., weekend and holiday interventions because they are special interventions not included in the Guarantee coverage and which therefore have an additional cost, will be carried out exclusively on request expressed by the Buyer and upon the availability of the Producer.

5. Warranty Inclusion

Solzaima, S.A. will correct without any charge to the Buyer the defects covered by the Warranty through the repair of the Product. The replaced Products or Components shall become the property of Solzaima, S.A.

6. Responsibility of Solzaima, S.A

Notwithstanding legally established, Solzaima, S.A., liability in respect of warranty is limited to that established in the present warranty conditions.

7. Cost of Services performed outside the scope of the warranty

The interventions carried out outside the scope of the warranty are subject to the application of the current tariff.

8. Warranty Services performed out of scope Warranty

The interventions carried out outside the scope of the Warranty and carried out by the official technical assistance service of Solzaima have a 6-month guarantee.

9. Warranty Spare Parts provided by Solzaima

The Parts supplied by Solzaima, in the scope of the commercial sale of spare parts, that is, not incorporated in the equipment, do not have warranty.

10. Replaced Parts under the of Scope Technical Service

From the moment they are removed from the equipment, the Parts used are considered as waste. Solzaima as a producer of waste in the scope of its activity is obliged by the legislation in force to deliver them to a licensed entity that performs the proper waste management operations under the law and therefore is prevented from giving them another destination, whatever. Therefore, the customer will be able to see the used parts resulting from the assistance, but cannot keep them in their possession.

11. Administrative expenses

In the case of invoices for services rendered, they are not processed in any stipulated period with default interest at the maximum legal rate in force.

12. Competent court

For the resolution of any dispute arising from the purchase and sale agreement having as object the products covered by the warranty, the contracting parties attribute exclusive jurisdiction to the courts of the district of Águeda, with express waiver of any other..

27. Annexes

27.1. Timer weekly programming (not applicable to Columbus Electronics)

Nº Programa	Dias	Programas horarios																							
		0	1	2	3	4	5	6	7	8	9	10	11	12	13	14	15	16	17	18	19	20	21	22	23
P01	Seg-Sex																								
	Sab-Dom																								
P02	Seg-Sex																								
	Sab-Dom																								
P03	Seg-Sex																								
	Sab-Dom																								
P04	Seg-Sex																								
	Sab-Dom																								
P05	Seg-Sab																								
	Dom																								
P06	Seg-Sex																								
	Sab-Dom																								
P07	Seg-Sex																								
	Sab-Dom																								
P08	Seg-Sex																								
	Sab-Dom																								
P09	Seg-Sex																								
	Sab-Dom																								
P10	Sex																								
	Sab-Dom																								

Note: the compact is active in the filled in squares and deactivated in the blank squares.

27.2. Flow Chart

• Flow chart 1 – Lighting

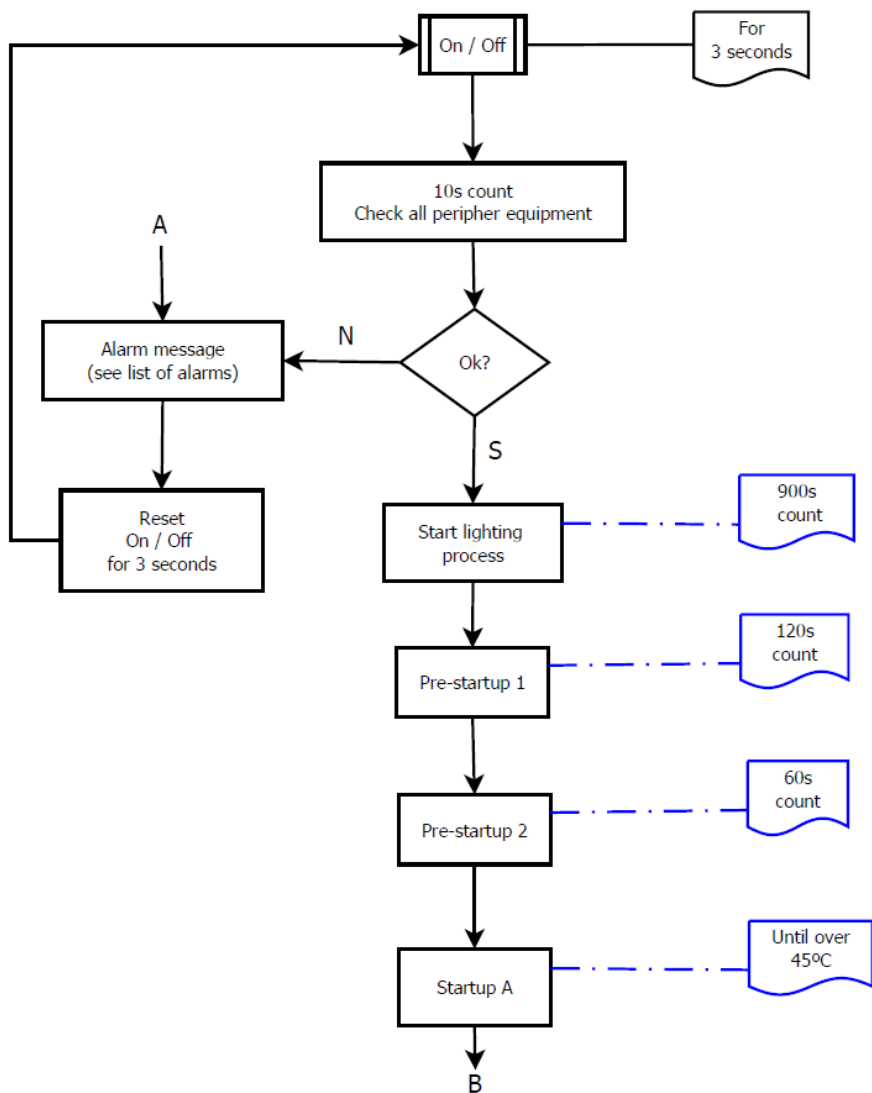

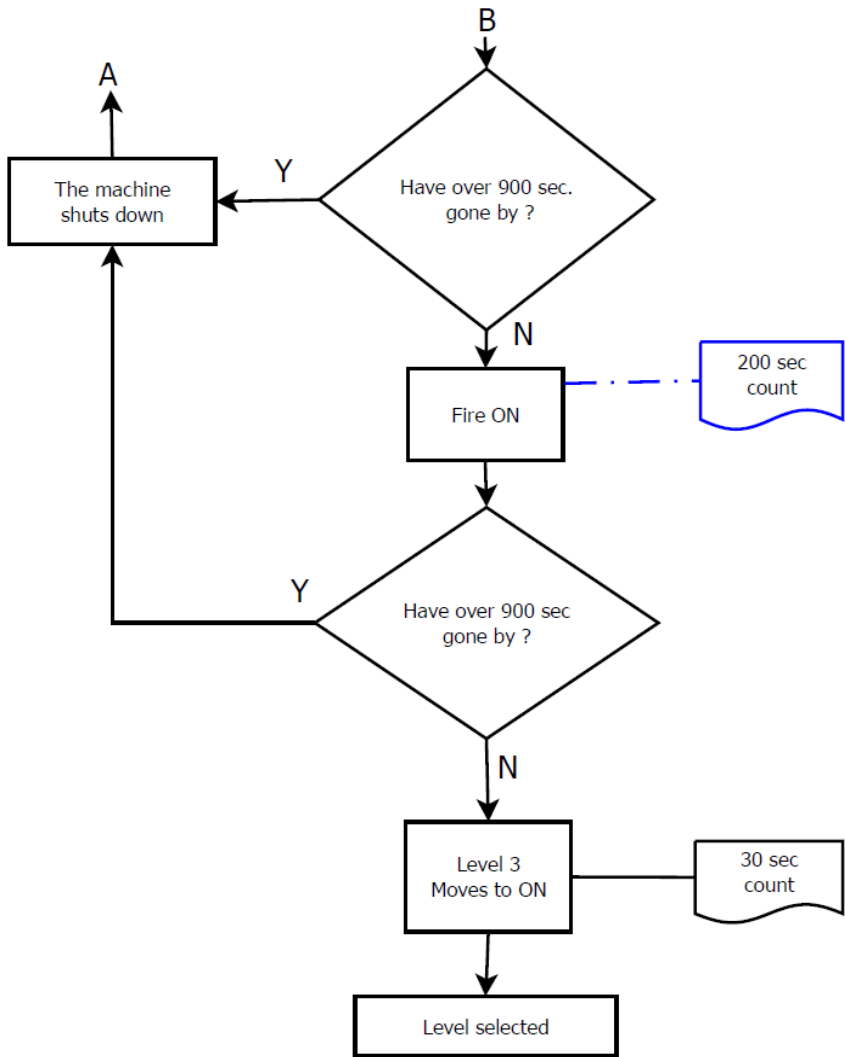

• Flow chart 2 – Disabling

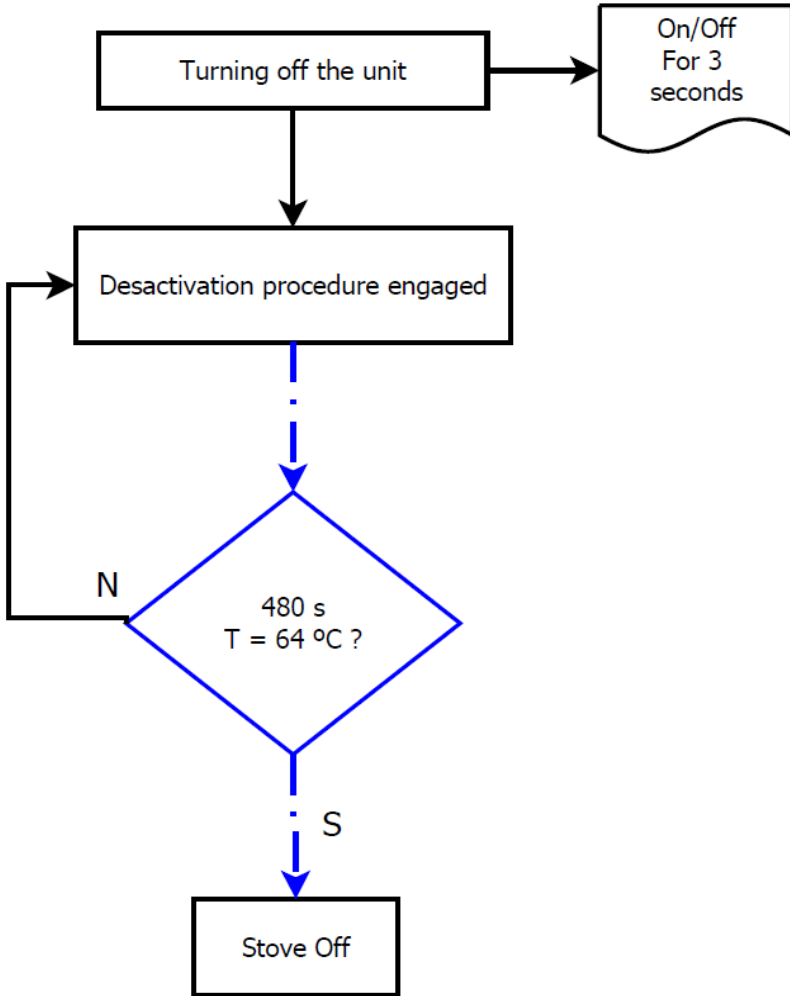

Note: The circulator pump off below 40 °C water temperature.

28. Declaration of Performance

DECLARAÇÃO DE DESEMPENHO | DECLARACIÓN PRESTACIONES | DECLARATION OF PERFORMANCE |
DÉCLARATION DE PERFORMANCE | DICHIARAZIONE DELLE PRESTAZIONI

Nº DD-075

1. Código de identificação único do produto-tipo | Código de identificación único del tipo de producto |
Unique identification code of the product type | Le code d'identification unique du type de produit | Codice
unico di identificazione del tipo di prodotto

COMPACTA SZMECO C 12 KW – EAN 05600990465077

2. Número do tipo, lote ou série do produto | Número de tipo, lote o serie del producto | Number of type,
batch or serial product | Nombre de type, de lot ou de série du produit | Numero di tipo, di lotto, di serie del
prodotto

3. Utilização prevista | Uso previsto | Intended use | Utilisation prévue | Destinazione d'uso

AQUECIMENTO DE EDIFÍCIOS DE HABITAÇÃO | CALEFACCIÓN DE EDIFICIOS RESIDENCIALES | HEATING
OF RESIDENTIAL BUILDINGS | CHAUFFAGE DE BATIMENTS RESIDENTIELS | RISCALDAMENTO DEGLI EDIFICI
RESIDENZIALI

4. Nome, designação comercial registada e endereço de contacto do fabricante | Nombre, marca registrada y
la dirección de contacto de lo fabricante | Name, registered trade name and contact address of the
manufacturer | Nom, marque déposée et l'adresse de contact du fabricant | Nome, denominazione
commerciale registrata e Indirizzo del costruttore

SOLZAIMA, SA
RUA DOS OUTARELOS, Nº 111
3750-362 BELAZAIMA DO CHÃO – ÁGUEDA – PORTUGAL

5. Sistema de avaliação e verificação da regularidade do desempenho do produto | Sistema de evaluación y
verificación de constancia de las prestaciones del producto | System of assessment and verification of constancy
of the product | Système d'évaluation et de vérification de la Constance des performances du produit |
Sistema di valutazione e verifica della costanza della prestazione del prodotto

SISTEMA 3

6. Norma Harmonizada | Estandár armonizado | Harmonized standard | Norme harmonisée | Standard
armonizzata

EN 14785

7. Nome e número de identificação do organismo notificado | Nombre y número de identificación del
organismo notificado | Name and identification number of the notified body | Nom et numéro
d'identification de l'organisme notifié | Nome e numero di identificazione dell'organismo notificato

CEIS
NB: 1722

8. Relatório de ensaio | Informe de la prueba | Test report | Rapport d'essai | Rapporto di prova

CEE-0257/19-1 Rv1

<p>Características essenciais Características esenciales Essencial characteristics Caractéristiques essentielles Caratteristiche essenziali</p>	<p>Desempenho Desempeño Performance Prestazione</p>	<p>Especificações técnicas harmonizadas Especificaciones técnicas armonizadas Harmonized technical specifications Spécifications techniques harmonisées Specifiche tecniche armonizzate</p>
<p>Segurança contra incêndio Seguridad contra incendios Fire safety Sécurité incendie Sicurezza antincendio</p>	<p>OK. De acordo com relatório de ensaio De acuerdo con informe de la prueba According to the test report Selons le rapport d'essai Secondo i rapporto di prova CEE-0257/19-1 Rv1</p>	<p>De acordo com os requisitos De acuerdo con los requisitos According to the requirements Selons les exigences Secondo i requisiti 4.2, 4.3, 4.7, 4.8, 4.10, 4.11, 5.1, 5.3, 5.4, 5.5, 5.8 (EN14785)</p>
<p>Emissão de produtos da combustão La emisión de productos de combustión Emission of combustion products Emission des produits de combustion Emissione dei prodotti di combustione</p>	<p>OK. Caudal térmico nominal Caudal térmico nominal Nominal heat output Le débit calorifique nominal Nominal heat output Flusso termico nominale –CO:0,0136%</p>	<p>Caudal térmico nominal Caudal térmico nominal Nominal heat output Le débit calorifique nominal Nominal heat output Flusso termico nominale –CO<0,04%</p>
	<p>OK. Caudal térmico reduzido Flujo térmico reducido Reduced thermal flow Flux thermique réduit Flusso termico ridotto –CO: 0,0256%</p>	<p>Caudal térmico reduzido Flujo térmico reducido Reduced thermal flow Flux thermique réduit Flusso termico ridotto –CO<0,06%</p>
<p>Libertação de substâncias perigosas Emisión de sustancias peligrosas Release of dangerous substances Dégagement de substances Rilascio di sostanze pericolose</p>	<p>OK. De acordo com relatório de ensaio De acuerdo con informe de la prueba According to the test report Selons le rapport d'essai Secondo i rapporto di prova CEE-0257/19-1 Rv1</p>	<p>De acordo com o Anexo ZA.1 (EN14785) De acuerdo con lo Anexo ZA.1 (EN14785) According to the Annex ZA.1 (EN14785) Selons le Annexe ZA.1 (EN14785) Secondo l'allegato ZA.1 (EN14785)</p>
<p>Temperatura de superfície Temperatura de la superficie Surface temperature La température de surface Temperatura superficiale</p>	<p>OK. De acordo com relatório de ensaio De acuerdo con informe de la prueba According to the test report Selons le rapport d'essai Secondo i rapporto di prova CEE-0257/19-1 Rv1</p>	<p>De acordo com os requisitos De acuerdo con los requisitos According to the requirements Selons les exigences Secondo i requisiti 4.2, 4.13, 5.1, 5.2, 5.4, 5.5 (EN14785)</p>
<p>Segurança eléctrica Seguridad eléctrica Electrical safety Sécurité électrique Sicurezza elettrica</p>	<p>OK. De acordo com relatório de ensaio De acuerdo con informe de la prueba According to the test report Selons le rapport d'essai Secondo i rapporto di prova CEE-0257/19-1 Rv1</p>	<p>De acordo com os requisitos De acuerdo con los requisitos According to the requirements Selons les exigences Secondo i requisiti 5.9 (EN14785)</p>
<p>Aptidão para ser limpo Capacidad para ser limpiado Ability to be cleaned Possibilité d'être nettoyé Capacità di essere puliti</p>	<p>OK. De acordo com relatório de ensaio De acuerdo con informe de la prueba According to the test report Selons le rapport d'essai Secondo i rapporto di prova CEE-0257/19-1 Rv1</p>	<p>De acordo com os requisitos De acuerdo con los requisitos According to the requirements Selons les exigences Secondo i requisiti 4.5, 4.6, 4.10, 4.12 (EN14785)</p>
<p>Temperatura dos gases de combustão Temperatura de los gases de combustión Temperature of the flue gas Température du gaz de fumée Temperatura dato fumi</p>	<p>OK. 108 °C</p>	<p>De acordo com os requisitos De acuerdo con los requisitos According to the requirements Selons les exigences Secondo i requisiti 6.2 (EN14785)</p>

Resistência mecânica Resistencia mecânica Mechanical strength résistance Resistenza meccanico	OK. De acordo com relatório de ensaio De acuerdo con informe de la prueba According to the test report Selons le rapport d'essai Secondo i rapporto di prova CEE-0257/19-1 Rv1 A cada 10 m de conduta de fumos deve ser colocado um suporte de carga cada 10 m de la salida de humos se debe colocar un soporte de carga every 10 m of the flue should be placed a load support tous les 10 m de conduit de fumée doit être placé un support de charge ogni 10 m della canna fumaria deve essere posto un supporto di carico	De acordo com os requisitos De acuerdo con los requisitos According to the requirements Selons les exigences Secondo i requisiti 4.2, 4.3(EN14785)
Potência térmica nominal Potencia térmica nominal Nominal Thermic output Puissance thermique nominale Potenza térmica nominale	OK. 13 kW	De acordo com os requisitos De acuerdo con los requisitos According to the requirements Selons les exigences Secondo i requisiti 6.1, 6.4 – 6.10 (EN14785)
Potência térmica reduzida Potencia térmica reducida Reduced Thermic output Puissance thermique réduite Potenza térmica ridotta	OK. 5 kW	De acordo com os requisitos De acuerdo con los requisitos According to the requirements Selons les exigences Secondo i requisiti 6.1, 6.4 – 6.10 (EN14785)
Rendimento energético Eficiencia energética Energy efficiency L'efficacité énergétique Efficienza energetica	OK. 92 %	≥ 75% para potência térmica nominal de potencia térmica nominal for rated thermal input Pour puissance thermique nominale di potenza termica nominale
	OK. 95 %	≥ 70% para potência térmica reduzida la reducción térmica to reduced thermal à la réduction thermique di potenza térmica ridotto
Durabilidade Durabilidad Durability Durabilité Durabilità	OK. De acordo com relatório de ensaio De acuerdo con informe de la prueba According to the test report Selons le rapport d'essai Secondo i rapporto di prova CEE-0257/19-1 Rv1	De acordo com os requisitos De acuerdo con los requisitos According to the requirements Selons les exigences Secondo i requisiti 4.2 (EN14785)

10. O desempenho do produto declarado nos pontos 1 e 2 é conforme com o desempenho declarado no ponto 9. A presente declaração de desempenho é emitida sob exclusiva responsabilidade do fabricante identificado no ponto 4. | El funcionamiento del producto se indica en los puntos 1 y 2 es compatible con las prestaciones declaradas en el punto 9. La presente declaración se expide bajo la exclusiva responsabilidad del fabricante identificado en lo punto 4. | Performance of the product stated in points 1 and 2 is consistent with the declared performance in point 9. This declaration of performance is issued under the sole responsibility of the manufacturer identified in point 4. | Les performances du produit indiqué dans les points 1 et 2 est compatible avec les performances declares au point 9. Cette declaration de performance est établie sous la seule responsabilité du fabricant identifié dans le point 4. | Le prestazioni dei prodotti indicati ai punti 1 e 2 è conforme alla prestazione dichiarata al punto 9. Questa dichiarazione di prestazione è rilasciata sotto l'esclusiva responsabilità del fabbricante di cui al punto 4

Nome e cargo | Nombre y cargo | Name and title | Nom et titre | Nome e titolo
Nuno Sequeira (Director Geral | CEO)

Belazaima do Chão, 20/04/2021

DECLARAÇÃO DE DESEMPENHO | DECLARACIÓN PRESTACIONES | DECLARATION OF PERFORMANCE |
DÉCLARATION DE PERFORMANCE | DICHIARAZIONE DELLE PRESTAZIONI

Nº DD-076

1. Código de identificação único do produto-tipo | Código de identificación único del tipo de producto | Unique identification code of the product type | Le code d'identification unique du type de produit | Codice unico di identificazione del tipo di prodotto

COMPACTA SZMECO C 18 KW – EAN 05600990465084

2. Número do tipo, lote ou série do produto | Número de tipo, lote o serie del producto | Number of type, batch or serial product | Nombre de type, de lot ou de série du produit | Numero di tipo, di lotto, di serie del prodotto

3. Utilização prevista | Uso previsto | Intended use | Utilisation prévue | Destinazione d'uso

AQUECIMENTO DE EDIFÍCIOS DE HABITAÇÃO | CALEFACCIÓN DE EDIFICIOS RESIDENCIALES | HEATING OF RESIDENTIAL BUILDINGS | CHAUFFAGE DE BATIMENTS RESIDENTIELS | RISCALDAMENTO DEGLI EDIFICI RESIDENZIALI

4. Nome, designação comercial registada e endereço de contacto do fabricante | Nombre, marca registrada y la dirección de contacto de lo fabricante | Name, registered trade name and contact address of the manufacturer | Nom, marque déposée et l'adresse de contact du fabricant | Nome, denominazione commerciale registrata e Indirizzo del costruttore

SOLZAIMA, SA
RUA DOS OUTARELOS, Nº 111
3750-362 BELAZAIMA DO CHÃO – ÁGUEDA – PORTUGAL

5. Sistema de avaliação e verificação da regularidade do desempenho do produto | Sistema de evaluación y verificación de constancia de las prestaciones del producto | System of assessment and verification of constancy of the product | Système d'évaluation et de vérification de la Constance des performances du produit | Sistema di valutazione e verifica della costanza della prestazione del prodotto

SISTEMA 3

6. Norma Harmonizada | Estandár armonizado | Harmonized standard | Norme harmonisée | Standard armonizzata

EN 14785

7. Nome e número de identificação do organismo notificado | Nombre y número de identificación del organismo notificado | Name and identification number of the notified body | Nom et numéro d'identification de l'organisme notifié | Nome e numero di identificazione dell'organismo notificato

CEIS
NB: 1722

8. Relatório de ensaio | Informe de la prueba | Test report | Rapport d'essai | Rapporto di prova

CEE-0257/19-1 RV1
CEE-0116/20-1

9. Desempenho declarado | Desempeño declarado | Declared performance | Performance
 déclarée | Dichiarazione di prestazione

Características essenciais Características esenciales Essencial characteristics Caractéristiques essentielles Caratteristiche essenziali	Desempenho Desempeño Performance Prestazione	Especificações técnicas harmonizadas Especificaciones técnicas armonizadas Harmonized technical specifications Spécifications techniques harmonisées Specifiche tecniche armonizzate
Segurança contra incêndio Seguridad contra incendios Fire safety Sécurité incendie Sicurezza antincendio	OK. De acordo com relatório de ensaio De acuerdo com informe de la prueba According to the test report Selons le rapport d'essai Secondo i rapporto di prova CEE-0257/19-1 Rv1 CEE-0116/20-1	De acordo com os requisitos De acuerdo con los requisitos According to the requirements Selons les exigences Secondo i requisiti 4.2, 4.3, 4.7, 4.8, 4.10, 4.11, 5.1, 5.3, 5.4, 5.5, 5.8 (EN14785)
Emissão de produtos da combustão La emisión de productos de combustión Emission of combustion products Emission des produits de combustion Emissione dei prodotti di combustione	OK. Caudal térmico nominal Caudal térmico nominale Nominal heat output Le débit calorifique nominal Nominal heat output Flusso termico nominale – CO:0,0159%	Caudal térmico nominal Caudal térmico nominale Nominal heat output Le débit calorifique nominal Nominal heat output Flusso termico nominale – CO<0,04%
	OK. Caudal térmico reduzido Flujo térmico reducido Reduced thermal flow Flux thermique réduit Flusso termico ridotto – CO: 0,0300%	Caudal térmico reduzido Flujo térmico reducido Reduced thermal flow Flux thermique réduit Flusso termico ridotto – CO<0,06%
Libertação de substâncias perigosas Emisión de sustancias peligrosas Release of dangerous substances Dégagement de substances Rilascio di sostanze pericolose	OK. De acordo com relatório de ensaio De acuerdo com informe de la prueba According to the test report Selons le rapport d'essai Secondo i rapporto di prova CEE-0257/19-1 Rv1 CEE-0116/20-1	De acordo com o Anexo ZA.1 (EN14785) De acuerdo con lo Anexo ZA.1 (EN14785) According to the Annex ZA.1 (EN14785) Selons le Annexe ZA.1 (EN14785) Secondo l'allegato ZA.1 (EN14785)
Temperatura de superfície Temperatura de la superficie Surface temperature La température de surface Temperatura superficiale	OK. De acordo com relatório de ensaio De acuerdo com informe de la prueba According to the test report Selons le rapport d'essai Secondo i rapporto di prova CEE-0257/19-1 Rv1 CEE-0116/20-1	De acordo com os requisitos De acuerdo con los requisitos According to the requirements Selons les exigences Secondo i requisitos 4.2, 4.13, 5.1, 5.2, 5.4, 5.5 (EN14785)
Segurança eléctrica Seguridad eléctrica Electrical safety Sécurité électrique sicurezza elettrica	OK. De acordo com relatório de ensaio De acuerdo com informe de la prueba According to the test report Selons le rapport d'essai Secondo i rapporto di prova CEE-0257/19-1 Rv1 CEE-0116/20-1	De acordo com os requisitos De acuerdo con los requisitos According to the requirements Selons les exigences Secondo i requisiti 5.9 (EN14785)

<p>Aptidão para ser limpo Capacidad para ser limpiado Ability to be cleaned Possibilité d'être nettoyé Capacità di essere puliti</p>	<p>OK. De acordo com relatório de ensaio De acuerdo com informe de la prueba According to the test report Selons er apport d'essai Secondo i rapporto di prova CEE-0257/19-1 Rv1 CEE-0116/20-1</p>	<p>De acordo com os requisitos De acuerdo con los requisitos According to the requirements Selons les exigences Secondo i requisiti 4.5, 4.6, 4.10, 4.12 (EN14785)</p>
<p>Temperatura dos gases de combustão Temperatura de los gases de combustión Temperature of the flue gas Température du gaz de fumée Temperatura dato fumi</p>	<p>OK. 118,95 °C</p>	<p>De acordo com os requisitos De acuerdo con los requisitos According to the requirements Selons les exigences Secondo i requisiti 6.2 (EN14785)</p>
<p>Resistência mecânica Resistencia mecánica Mechanical strength résistance Resistenza meccanico</p>	<p>OK. De acordo com relatório de ensaio De acuerdo com informe de la prueba According to the test report Selons le rapport d'essai Secondo i rapporto di prova CEE-0257/19-1 Rv1 CEE-0116/20-1 A cada 10 m de conduta de fumos deve ser colocado um suporte de carga cada 10 m de la salida de humos se debe colocar un soporte de carga every 10 m of the flue should be placed a load support tous les 10 m de conduit de fumée doit être placé un support de charge ogni 10 m della canna fumaria deve essere posto un supporto di carico</p>	<p>De acordo com os requisitos De acuerdo con los requisitos According to the requirements Selons les exigences Secondo i requisiti 4.2, 4.3(EN14785)</p>
<p>Potência térmica nominal Potencia térmica nominal Nominal Thermic output Puissance thermique nominale Potenza térmica nominale</p>	<p>OK. 18 kW</p>	<p>De acordo com os requisitos De acuerdo con los requisitos According to the requirements Selons les exigences Secondo i requisiti 6.1, 6.4 – 6.10 (EN14785)</p>
<p>Potência térmica reduzida Potencia térmica reducida Reduced Thermic output Puissance thermique réduite Potenza térmica ridotta</p>	<p>OK. 6,3 kW</p>	<p>De acordo com os requisitos De acuerdo con los requisitos According to the requirements Selons les exigences Secondo i requisiti 6.1, 6.4 – 6.10 (EN14785)</p>
<p>Rendimento energético Eficiencia energética Energy efficiency L'efficacité énergétique Efficienza energetica</p>	<p>OK. 91,5 %</p>	<p>≥ 75% para potência térmica nominal de potencia térmica nominal for rated thermal input Pour puissance thermique nominale di potenza termica nominale</p>
	<p>OK. 95,0 %</p>	<p>≥ 70% para potência térmica reduzida la reducción térmica to reduced thermal à la réduction thermique di potenza térmica ridotto</p>

Durabilidade Durabilidad Durability Durabilité Durabilità	OK. De acordo com relatório de ensaio De acuerdo com informe de la prueba According to the test report Selons le rapport d'essai Secondo i rapporto di prova CEE-0257/19-1 Rv1 CEE-0116/20-1	De acordo com os requisitos De acuerdo con los requisitos According to the requirements Selons les exigences Secondo i requisiti 4.2 (EN14785)
---	--	--

10. O desempenho do produto declarado nos pontos 1 e 2 é conforme com o desempenho declarado no ponto 9. A presente declaração de desempenho é emitida sob exclusiva responsabilidade do fabricante identificado no ponto 4. | El funcionamiento del producto se indica en los puntos 1 y 2 es compatible con las prestaciones declaradas en el punto 9. La presente declaración se expide bajo la exclusiva responsabilidade del fabricante identificado en lo punto 4. | Performance of the product stated in points 1 and 2 is consistent with the declared performance in point 9. This declaration of performance is issued under the sole responsibility of the manufacturer identified in point 4. | Les performances du produit indiqué dans les points 1 et 2 est compatible avec les performances declares au point 9. Cette declaration de performance est établie sous la seule responsabilité du fabricant identifié dans le point 4. | Le prestazioni dei prodotti indicati ai punti 1 e 2 è conforme alla prestazione dichiarata al punto 9. Questa dichiarazione di prestazione è rilasciata sotto l'esclusiva responsabilità del fabbricante di cui al punto 4

Nome e cargo | Nombre y cargo | Name and title | Nom et titre | Nome e titolo
Nuno Sequeira (Director Geral | CEO)

Belazaima do Chão, 20/04/2021

DECLARAÇÃO DE DESEMPENHO | DECLARACIÓN PRESTACIONES | DECLARATION OF PERFORMANCE |
DÉCLARATION DE PERFORMANCE | DICHIARAZIONE DELLE PRESTAZIONI

Nº DD-077

1. Código de identificação único do produto-tipo | Código de identificación único del tipo de producto | Unique identification code of the product type | Le code d'identification unique du type de produit | Codice unico di identificazione del tipo di prodotto

COMPACTA SZMECO C 24 kW – EAN 05600990465091

2. Número do tipo, lote ou série do produto | Número de tipo, lote o serie del producto | Number of type, batch or serial product | Nombre de type, de lot ou de série du produit | Numero di tipo, di lotto, di serie del prodotto

3. Utilização prevista | Uso previsto | Intended use | Utilisation prévue | Destinazione d'uso

AQUECIMENTO DE EDIFÍCIOS DE HABITAÇÃO | CALEFACCIÓN DE EDIFICIOS RESIDENCIALES | HEATING OF RESIDENTIAL BUILDINGS | CHAUFFAGE DE BATIMENTS RESIDENTIELS | RISCALDAMENTO DEGLI EDIFICI RESIDENZIALI

4. Nome, designação comercial registada e endereço de contacto do fabricante | Nombre, marca registrada y la dirección de contacto de lo fabricante | Name, registered trade name and contact address of the manufacturer | Nom, marque déposée et l'adresse de contact du fabricant | Nome, denominazione commerciale registrata e Indirizzo del costruttore

SOLZAIMA, SA
RUA DOS OUTARELOS, Nº 111
3750-362 BELAZAIMA DO CHÃO – ÁGUEDA – PORTUGAL

5. Sistema de avaliação e verificação da regularidade do desempenho do produto | Sistema de evaluación y verificación de constancia de las prestaciones del producto | System of assessment and verification of constancy of the product | Système d'évaluation et de vérification de la Constance des performances du produit | Sistema di valutazione e verifica della costanza della prestazione del prodotto

SISTEMA 3

6. Norma Harmonizada | Estandár armonizado | Harmonized standard | Norme harmonisée | Standard armonizzata

EN 14785

7. Nome e número de identificação do organismo notificado | Nombre y número de identificación del organismo notificado | Name and identification number of the notified body | Nom et numéro d'identification de l'organisme notifié | Nome e numero di identificazione dell'organismo notificato

CEIS
NB: 1722

8. Relatório de ensaio | Informe de la prueba | Test report | Rapport d'essai | Rapporto di prova

CEE-0116/20-1

<p>Características essenciais Características esenciales Essencial characteristics Caractéristiques essentielles Caratteristiche essenziali</p>	<p>Desempenho Desempeño Performance Prestazione</p>	<p>Especificações técnicas harmonizadas Especificaciones técnicas armonizadas Harmonized technical specifications Spécifications techniques harmonisées Specifiche tecniche armonizzate</p>
<p>Segurança contra incêndio Seguridad contra incendios Fire safety Sécurité incendie Sicurezza antincendio</p>	<p>OK. De acordo com relatório de ensaio De acuerdo con informe de la prueba According to the test report Selons le rapport d'essai Secondo i rapporto di prova CEE-0116/20-1</p>	<p>De acordo com os requisitos De acuerdo con los requisitos According to the requirements Selons les exigences Secondo i requisiti 4.2, 4.3, 4.7, 4.8, 4.10, 4.11, 5.1, 5.3, 5.4, 5.5, 5.8 (EN14785)</p>
<p>Emissão de produtos da combustão La emisión de productos de combustión Emission of combustion products Emission des produits de combustion Emissione dei prodotti di combustione</p>	<p>OK. Caudal térmico nominal Caudal térmico nominale Nominal heat output Le débit calorifique nominal Nominal heat output Flusso termico nominale – CO:0,0184%</p>	<p>Caudal térmico nominal Caudal térmico nominale Nominal heat output Le débit calorifique nominal Nominal heat output Flusso termico nominale – CO<0,04%</p>
	<p>OK. Caudal térmico reduzido Flujo térmico reducido Reduced thermal flow Flux thermique réduit Flusso termico ridotto – CO: 0,0343%</p>	<p>Caudal térmico reduzido Flujo térmico reducido Reduced thermal flow Flux thermique réduit Flusso termico ridotto – CO<0,06%</p>
<p>Libertação de substâncias perigosas Emisión de sustancias peligrosas Release of dangerous substances Dégagement de substances Rilascio di sostanze pericolose</p>	<p>OK. De acordo com relatório de ensaio De acuerdo con informe de la prueba According to the test report Selons le rapport d'essai Secondo i rapporto di prova CEE-0116/20-1</p>	<p>De acordo com o Anexo ZA.1 (EN14785) De acuerdo con lo Anexo ZA.1 (EN14785) According to the Annex ZA.1 (EN14785) Selons le Annexe ZA.1 (EN14785) Secondo l'allegato ZA.1 (EN14785)</p>
<p>Temperatura de superfície Temperatura de la superficie Surface temperature La température de surface Temperatura superficiale</p>	<p>OK. De acordo com relatório de ensaio De acuerdo con informe de la prueba According to the test report Selons le rapport d'essai Secondo i rapporto di prova CEE-0116/20-1</p>	<p>De acordo com os requisitos De acuerdo con los requisitos According to the requirements Selons les exigences Secondo i requisiti 4.2, 4.13, 5.1, 5.2, 5.4, 5.5 (EN14785)</p>
<p>Segurança eléctrica Seguridad eléctrica Electrical safety Sécurité électrique Sicurezza elettrica</p>	<p>OK. De acordo com relatório de ensaio De acuerdo con informe de la prueba According to the test report Selons le rapport d'essai Secondo i rapporto di prova CEE-0116/20-1</p>	<p>De acordo com os requisitos De acuerdo con los requisitos According to the requirements Selons les exigences Secondo i requisiti 5.9 (EN14785)</p>
<p>Aptidão para ser limpo Capacidad para ser limpiado Ability to be cleaned Possibilité d'être nettoyé Capacità di essere puliti</p>	<p>OK. De acordo com relatório de ensaio De acuerdo con informe de la prueba According to the test report Selons le rapport d'essai Secondo i rapporto di prova CEE-0116/20-1</p>	<p>De acordo com os requisitos De acuerdo con los requisitos According to the requirements Selons les exigences Secondo i requisiti 4.5, 4.6, 4.10, 4.12 (EN14785)</p>
<p>Temperatura dos gases de combustão Temperatura de los gases de combustión Temperature of the flue gas Température du gaz de fumée Temperatura dato fumi</p>	<p>OK. 131°C</p>	<p>De acordo com os requisitos De acuerdo con los requisitos According to the requirements Selons les exigences Secondo i requisiti 6.2 (EN14785)</p>

Resistência mecânica Resistencia mecânica Mechanical strength résistance Resistenza meccanico	OK. De acordo com relatório de ensaio De acuerdo con informe de la prueba According to the test report Selons le rapport d'essai Secondo i rapporto di prova CEE-0116/20-1 A cada 10 m de conduita de fumos deve ser colocado un suporte de carga cada 10 m de la salida de humos se debe colocar un soporte de carga every 10 m of the flue should be placed a load support tous les 10 m de conduit de fumée doit être placé un support de charge ogni 10 m della canna fumaria deve essere posto un supporto di carico	De acordo com os requisitos De acuerdo con los requisitos According to the requirements Selons les exigences Secondo i requisiti 4.2, 4.3(EN14785)
Potência térmica Potencia térmica Thermic output Puissance thermique Potenza termico	OK. 23,5 kW	De acordo com os requisitos De acuerdo con los requisitos According to the requirements Selons les exigences Secondo i requisiti 6.1, 6.4 – 6.10 (EN14785)
Potência térmica reduzida Potencia térmica reducida Reduced Thermic output Puissance thermique réduite Potenza térmica ridotta	OK. 7,8 kW	De acordo com os requisitos De acuerdo con los requisitos According to the requirements Selons les exigences Secondo i requisiti 6.1, 6.4 – 6.10 (EN14785)
Rendimento energético Eficiencia energética Energy efficiency L'efficacité énergétique Efficienza energetica	OK. 91%	≥ 75% para potência térmica nominal de potencia térmica nominal for rated thermal input Pour puissance thermique nominale di potenza termica nominale
	OK. 95%	≥ 70% para potência térmica reduzida la reducción térmica to reduced thermal à la réduction thermique di potenza térmica ridotta
Durabilidade Durabilidad Durability Durabilité Durabilità	OK. De acordo com relatório de ensaio De acuerdo con informe de la prueba According to the test report Selons le rapport d'essai Secondo i rapporto di prova CEE-0116/20-1	De acordo com os requisitos De acuerdo con los requisitos According to the requirements Selons les exigences Secondo i requisiti 4.2 (EN14785)

10. O desempenho do produto declarado nos pontos 1 e 2 é conforme com o desempenho declarado no ponto 9. A presente declaração de desempenho é emitida sob exclusiva responsabilidade do fabricante identificado no ponto 4. | El funcionamiento del producto se indica en los puntos 1 y 2 es compatible con las prestaciones declaradas en el punto 9. La presente declaración se expide bajo la exclusiva responsabilidad del fabricante identificado en lo punto 4. | Performance of the product stated in points 1 and 2 is consistent with the declared performance in point 9. This declaration of performance is issued under the sole responsibility of the manufacturer identified in point 4. | Les performances du produit indiqué dans les points 1 et 2 est compatible avec les performances declares au point 9. Cette declaration de performance est établie sous la seule responsabilité du fabricant identifié dans le point 4. | Le prestazioni dei prodotti indicati ai punti 1 e 2 è conforme alla prestazione dichiarata al punto 9. Questa dichiarazione di prestazione è rilasciata sotto l'esclusiva responsabilità del fabbricante di cui al punto 4

Nome e cargo | Nombre y cargo | Name and title | Nom et titre | Nome e titolo
Nuno Sequeira (Director Geral | CEO)

Belazaima do Chão, 20/04/2021