

SOLZAIMA

SOLUÇÕES DE AQUECIMENTO A BIOMASSA

Wood Fired Boiler  
Instruction Manual  
English

Model

**Wood Fired Boiler SZM  
W Plus 25kW, 30kW,  
35kW and 40 kW**

Read these instructions carefully before installing, using and servicing the unit. The instruction manual is an integral part of the product.

Mod. 967-E

Thank you for purchasing a SOLZAIMA appliance.

Please read this manual carefully and keep it for future reference.

\* All our products fulfil the requirements of the Construction Products Directive (Directive 89/106/EEC) and have been approved with the CE conformity mark;

\* The Pellet Burning Free Standing Fires are designed according to EN 14785:2008 Standards;

\* SOLZAIMA disclaims any responsibility for damages to the unit if installed by non-qualified personnel;

\* SOLZAIMA is not responsible for any damage to units not installed and used in compliance to the instructions included in this manual;

\* All local regulations, including but not limited to national and European standards, must be observed when installing, operating and servicing the unit;

\* Whenever you need assistance, you should contact the supplier or installer of your equipment. You should provide the serial number of your stove that is located on the nameplate on the back of the equipment and on the sticker, s glued to the plastic cover of this manual.

\*The technical service must be performed by the unit Installer or Supplier, except on situations where the assessment performed by the installer or service engineer determines that SOLZAIMA should be contacted, if required.

**Contacts for technical support:**

[www.solzaima.pt](http://www.solzaima.pt)



[apoio.ciente@solzaima.pt](mailto:apoio.ciente@solzaima.pt)

Address: Rua da Cova da Areia (E.M. 605), 695;

3750-071 Aguada de Cima

Águeda – Portugal

# Contents

1. Package content.....	2
1.1. Unpacking the boiler.....	2
2. Safety Precautions  .....	2
2.1. For your safety, please remember .....	3
3. Technical Specifications.....	4
4. Wood Boiler Installation .....	9
5. Installing the Ventilation Kit (optional).....	9
6. Installation Requirements.....	14
7. Installing pipes and fume exhaust systems.....	16
8. Hydraulic Installation.....	17
8.1 Calculation for the minimum volume of the buffer tank .....	18
8.2 Method of calculating the volume expansion vessel.....	18
9. Fuel.....	20
10. First Use.....	22
11. Lighting.....	23
12. Maintenance and Cleaning  .....	23
13. Installation Diagrams .....	25
14. Life cycle of the wood fired boiler .....	28
15. Sustainability .....	28
16. Glossary.....	29
17. Warranty .....	31
17.1. Model specific conditions .....	31
17.2. Warranty General Conditions .....	31
18. Statement of Performance.....	40

## **Solzaima**

Solzaima's vision has always been to provide the cleanest, renewable and more cost-effective energy possible. This is why for more than 40 years we've been dedicated to manufacturing biomass heating units and solutions.

As a result of the persistence and unconditional support from a network of partners, Solzaima is currently the leader in biomass heating units manufacturing, supported by its range of central heating units with back boilers, pellet boilers and free-standing fires.

We deliver biomass heating units to approximately 20.000 homes every year. This effectively demonstrates consumers' interest in more ecological and economic solutions.

Solzaima has been awarded Quality certification under ISO 9001:2015 and Environmental certification under ISO 14001:2015.

## 1. Package content

The packaging of the equipment has the following contents:

- Wood Fired Boiler SZM W Plus;
- Packaging with the covers and insulation;
- Manual Instruction Brochure;
- Installer's brochure;
- Characteristics label;
- Energy efficiency label;
- Poker.

### 1.1. Unpacking the boiler

To unpack the equipment, you should remove the retractable bag that surrounds the boiler.

## 2. Safety Precautions

Solzaima shall not be liable for any damages to the unit caused by failure to comply with the specified precautions, warnings and operating procedures.

The units manufactured by Solzaima are easy to operate, special attention was given to their components to prevent accidental damages to users and installers.

The units must only be installed by an authorised engineer, who should supply the client with a relevant statement of conformity and who shall be liable for the final installation and consequent product good operating conditions.

This unit must be used according to its intended use as specified by the manufacturer. The manufacturer excludes all contractual or non-contractual obligations regarding damages to people, animals or property arising from the unit's misuse, faulty installation or servicing procedure.

After removing the packaging, verify the contents to check their integrity and completeness. If the contents of the package do not correspond to the items listed under 1, contact the sales representative from whom you purchased the unit.

The complete set of parts provided with the unit guarantees its operation and energy efficiency; these parts should only be replaced with original parts provided by an authorised technical assistance centre.

The unit must be subject to maintenance at least once a year by the installation engineer.

This manual is provided with the product. Please keep it close to the unit.

### **2.1. For your safety, please remember**

- The wood fired boiler is a biomass heating unit. Be sure to carefully read and understand the information contained in this book, before handling or operating the unit;
- Make sure the hydraulic circuit is correctly assembled and connected to the water supply system before turning on the wood fired boiler;
- The boiler is not intended for use by children or persons with a physical, sensory or mental handicap, unexperienced or unaware of its proper use, unsupervised or not instructed concerning the use of the unit;
- Do not touch the boiler when barefoot or any part of your body is wet or humid;
- Do not tamper with any safety or adjustment features of the unit without the manufacturer's authorisation;
- Do not cover or reduce the size of the aeration vents existing near the installation area;
- The wood fired boiler needs air circulation for proper combustion, so possible air tightness of the location or any existing air extraction sources in the room may prevent the unit's proper operation;
- Aeration openings are indispensable for proper combustion. This device must be installed in a place where the outside air can enter freely. Any air intake grilles must be placed in a non-blocking location so that sufficient air is available at the installation site, avoiding poor draught;
- Do not leave the packing materials near children;
- During the unit's normal operation do not attempt to open the boiler's door;
- Avoid direct contact with parts of the unit that overheat during operation;
- Check the fume duct for blockages before turning on the unit after a long period of inactivity;
- This pellet boiler is intended for residential use in a protected environment.

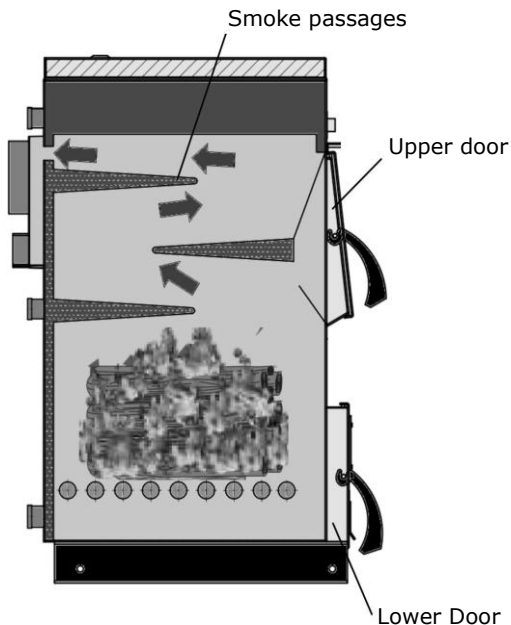
### 3. Technical Specifications

The Wood Fired Boiler SMZ W PLUS is intended for heating water for domestic use and to provide central heating. This requires the pre-installation of a central heating system, and a hot water tank equipped with a heat exchanger (if you wish to use the appliance to supply domestic hot water).

The Wood Fired Boiler SZM W PLUS is equipped with a large wood capacity combustion chamber (Figure 1), sturdy and user-friendly. This is an atmospheric (natural draught) boiler.

The boiler is equipped with two doors:

- Lower door: provides access to the area where the ashes fall through the grids, for cleaning purposes. It is equipped with a lid for the connection of the combustion auto-regulator. This regulator controls the water temperature inside the appliance, preventing it to become too hot when the removed heating power is lower than the produced heating power.
- Upper door: provides access to the wood supply channel and it is where the combustion occurs.



**Figure 1 - Section views of the combustion chamber of the wood fired boiler**

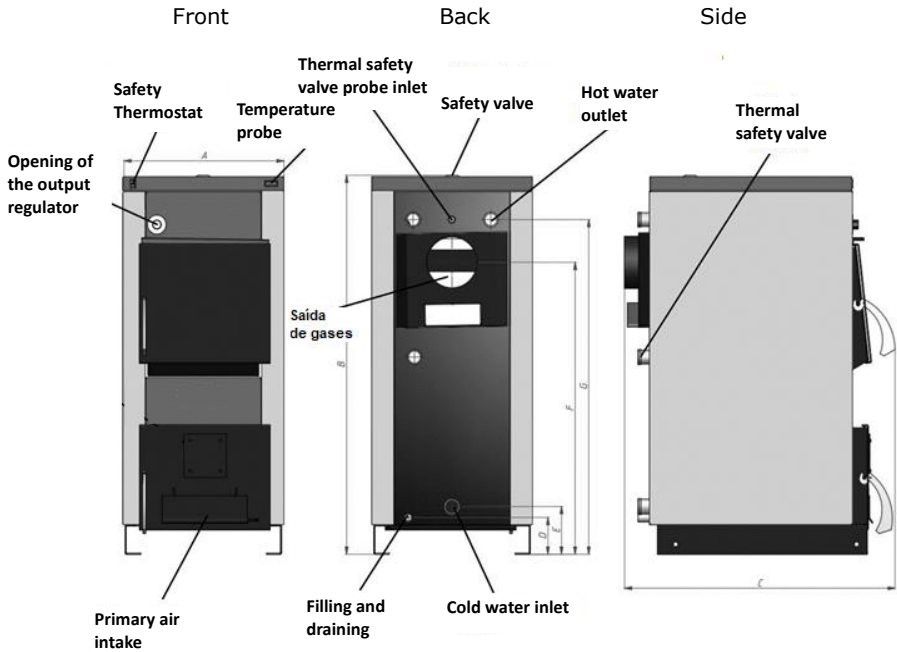
<b>Specifications</b>	<b>Boiler W Plus 25 kW</b>	<b>Boiler W Plus 30 kW</b>	<b>Boiler W Plus 35 kW</b>	<b>Boiler W Plus 40 kW</b>	<b>Units</b>
Weight	281	295	305	320	kg
Height [B]	1260	1260	1260	1260	mm
Width [A]	530	590	620	670	mm
Depth [C]	1100	1100	1100	1100	mm
Height discharging [D]	150	150	150	150	mm
Height return line [E]	170	170	170	170	mm
Height flue connection [F]	1010	1005	1005	1005	mm
Height flow (hot line) [G]	1170	1170	1170	1170	mm
Diameter of the fume discharge pipe	160	180	180	180	mm
Maximum heating capacity	568	682	795	909	m <sup>3</sup>
Wood log maximum length	500	500	500	500	mm
Maximum thermal power (water)	25	30	35	40	kW
Fuel consumption	4,95	5,9	6,9	7,9	kg/h
* Thermal yield at reduced thermal power	89,8	90,2	90,6	90,7	%
** Thermal yield at rated thermal power	80	80	80	80	%
CO Emissions with 10% O <sub>2</sub>	0,044	0,045	0,045	0,046	%
Max. gas temperature	193	191,5	190	195,7	°C
Max operating pressure	3	3	3	3	bar
Draught in the chimney	18	19	20	21	Pa
Water volume	75	90	105	120	L

**Table 1 - Technical specifications**

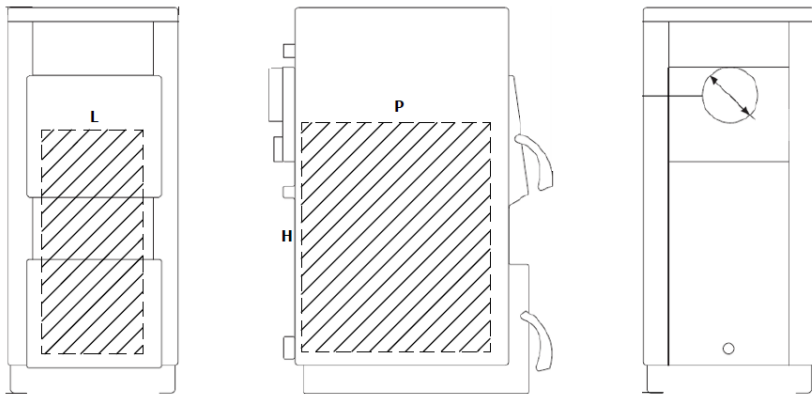
\* Tests performed using fuel with a calorific value of 5,08 kWh/kg and a humidity level of less than 6%.

\*\*Tests performed using fuel with a calorific value of 4,2 kWh/kg and a humidity level of 16% to 20%.

The above data were obtained in the product type approval tests at independent and accredited laboratories to test biomass combustion equipment.



**Figure 2 - Hydraulic connections**



**Table 2 - Combustion chamber dimensions**

Variables (Width/Height/Depth)	Boiler W Plus 25 kW	Boiler W Plus 30 kW	Boiler W Plus 35 kW	Boiler W Plus 40 kW	Un
L-Combustion Chamber Width	320	370	410	460	mm
H-Combustion chamber height	370	370	370	370	mm
P-Combustion Chamber Depth	550	550	550	550	mm



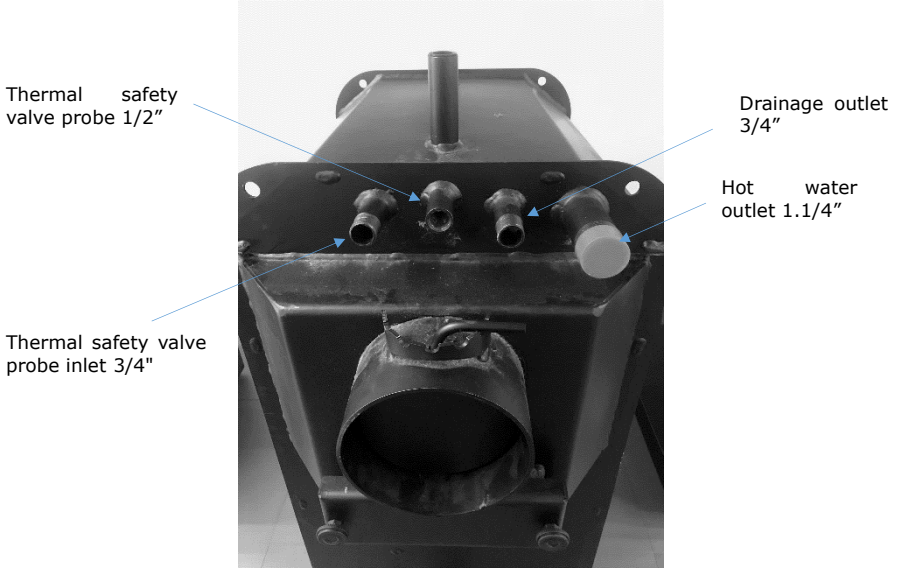
Opening of the  
output regulator  $\frac{3}{4}$ "

a)

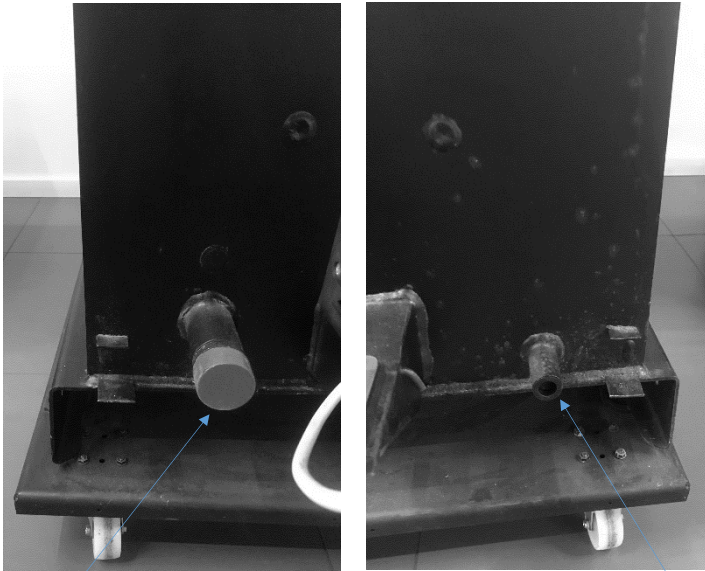


Placing the  
probe  $\frac{1}{2}$ "

b)



c)



d)

Cold water inlet 1.1/4"

Filling and draining 1/2"

**Figure 3 - Hydraulic connections**

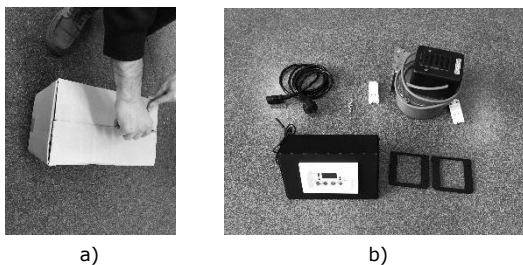
## 4. Wood Boiler Installation

Before starting the installation, perform the following actions:

- Check immediately after receipt if the delivered product is complete and in good condition. Any defects should be noted before installing the appliance.
- Remove the user manual and hand it to the customer.
- Connecting conduit 140 mm in diameter between the flue gas outlet port and a flue gas exhaust duct to the outside of the building (ex. chimney).
- Do the hydraulic installation (see section 13).

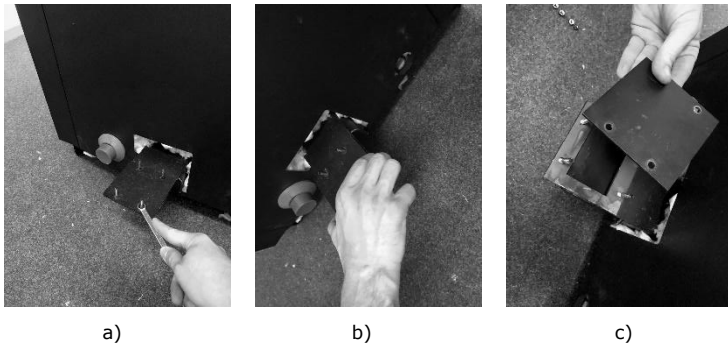
## 5. Installing the Ventilation Kit (optional)

Before installing the ventilation kit, you should immediately check that the kit is complete and in perfect condition (Figure 4), any damage or lack of elements should be reported and marked before proceeding with its installation. This chapter will demonstrate how the optional ventilation kit should be installed.



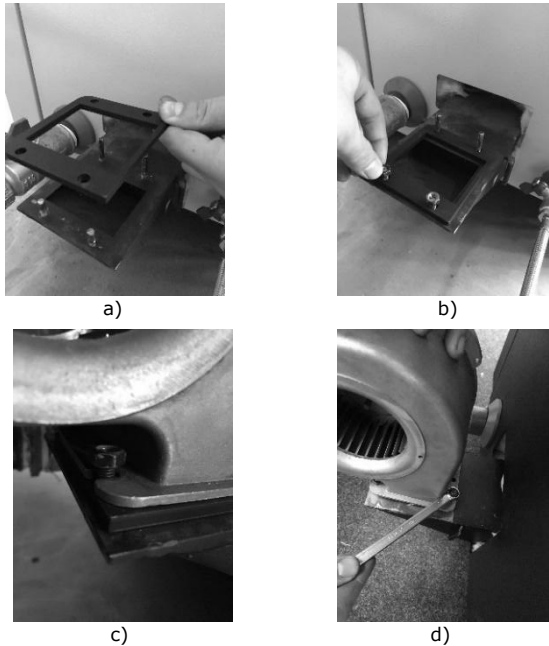
**Figure 4 – Ventilation Kit Optional**

1 – Remove the nuts and the air intake cover as shown in Figure 5.



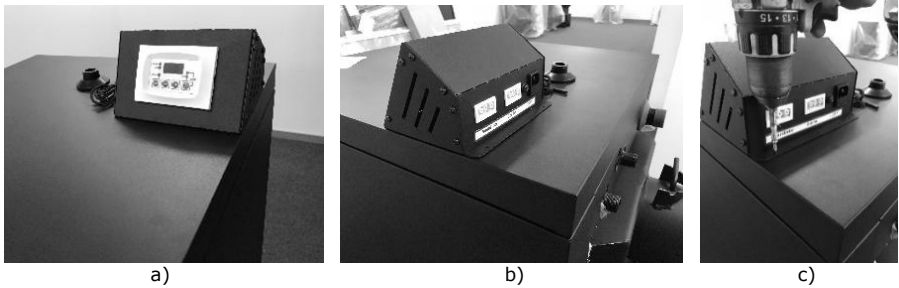
**Figure 5 – Remove the cap**

2 – Place the two flanges on the fan bracket (Figure 6-a), first point the two nuts as shown in Figure 6-b. Place the fan on the bracket (Figure 6-c), finally point the last two nuts and tighten everything to the end as exemplified in Figure 6-d.



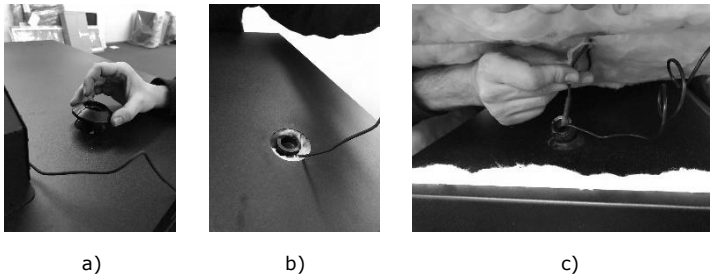
**Figure 6 – Placing the fan**

3 – Place the controller on top of the boiler so that it is able to connect the fan cable and is aligned with the side enclosure, as exemplified in Figure 7-a and Figure 7-b, fix the controller with the 3 self-piercing screws as exemplified in Figure 7-c.



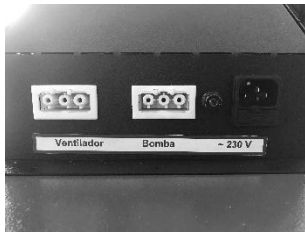
**Figure 7 – Placement of the fan controller**

4 – Place the temperature probe of the controller on top of the boiler as shown in Figure 8-a, 8-b and 8-c, and fit the enclosure back correctly.

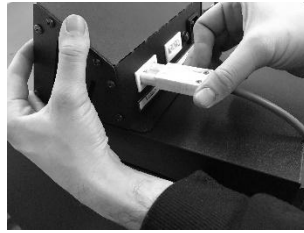


**Figure 8 – Placement of the temperature probe**

5 – The controller has two connections, one to the circulator and one to the fan (Figure 9-a), connect the fan cable to the controller on the corresponding plug (Figure 9-b), connect the power cable (Figure 9-c), and connect to the circulator of the Figure 9-d installation.



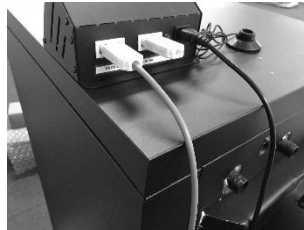
a)



b)



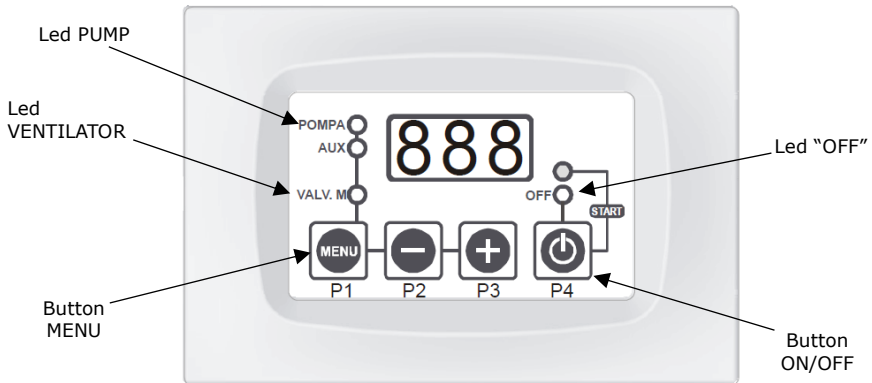
c)



d)

**Figure 9 – Placing the wiring**

6 – To start the fan just press the "ON/OFF" button (P4), the controller will order the fan (VALV M) to start and it will work until the "PUMP" Set Point temperature is reached (note: Fan Set Point (VALV M) must be the same as Pump Set Point, e.g. 60°C), at that moment the pump led lights up and the pump starts to work, when the firewood load is finished and the temperature of the pump Set Point drops, the fan starts again for a period of 15 min after that time, if the temperature does not reach the Set Point value of "VALV M" the fan switches off. To start the fan again, it will be necessary to give the order manually.



**Figure 10 – Display**

7 – To change the Pump Set Point on the controller, press the “MENU (P1)” button once, the Set Point value of the pump appears (the controller has a serial Set Point of 60°C), press the “+ (P2)” or “- (P3)” button to increase or decrease the Set Point temperature (it is recommended to set the Set Point value greater than or equal to 60°C), to return to the initial menu simply press the “MENU (P1)” button 3 times.

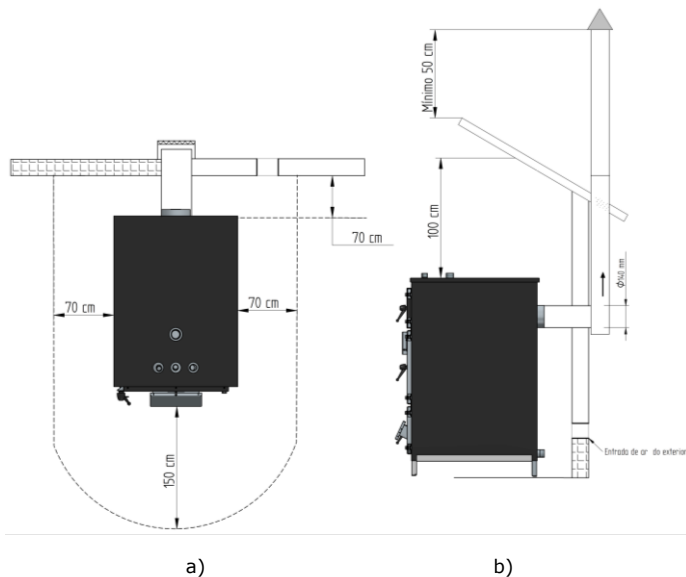
8 – To change the fan Set Point (VALV M) on the controller, press the “MENU (P1)” button three times, the set point value of “VALV M” appears (the controller has a serial set point of 60°C), press the “+ (P2)” or “- (P3)” button to increase or decrease the set point temperature (it is recommended to set the set point value greater than or equal to 60°C), to return to the initial menu simply press the “MENU (P1)” button once.

To turn the controller off, press the “ON/OFF (P4)” button until the OFF led is turned on, to turn the controller back on, press the “ON/OFF (P4)” button again until the boiler temperature appears.

## 6. Installation Requirements

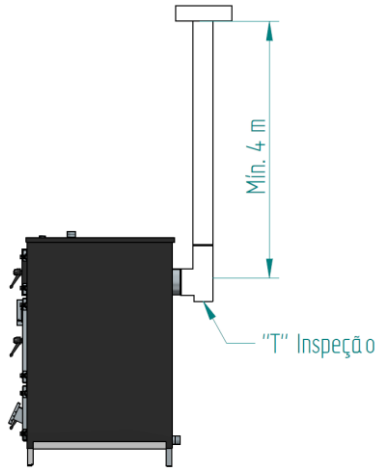
The minimum distances from the wood boiler to flammable surfaces are shown in Figure 11.

At the top of wood boiler, it is necessary to maintain a minimum distance of 100 cm from the ceiling of the room especially if they contain flammable material in their composition. The base on which the boiler is supported must not be of combustible material, so adequate protection must always be provided.

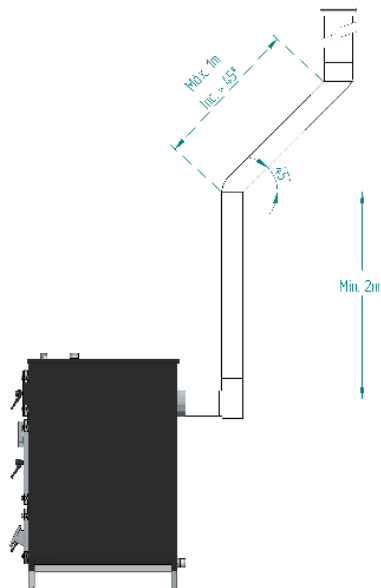


**Figure 11 – Minimum distances to all surfaces: a) top view of the installation of equipment; b) side view of the installation device**

In Figure 12 and Figure 13, the basic requirements for the installation of the boiler flue are shown. Provide a T for the periodic inspections and the annual maintenance, as exemplified in the figures. Double-walled insulated stainless-steel pipes should be used properly to avoid condensation.



**Figure 12 – Side view of the installation, with the inspection point**





**Figure 13 – Example of typical installation**


**! NOTICE!**

Keep combustible and flammable materials at a safe distance.

## 7. Installing pipes and fume exhaust systems

- The construction of the gas exhaust pipe must be suitable for the purpose in accordance with local requirements and respecting the regulations.
-  Important! An inspection T must be inserted at the outlet of the exhaust pipe of the wood-fired boiler with an airtight cover to permit regular inspection or discharge of heavy dust and condensate.
- The exhaust duct must be mounted in such a way that cleaning and maintenance is ensured by insertion of the inspection points.
- Under normal operating conditions, the drawdown of the combustion gases must lead to a depression depending on the of 18 to 21 Pa, measured 1,5 m above the boiler outlet.
- The wood boiler cannot share the chimney with other equipment.
- The chimneys installed outside the house must be double walled in stainless steel.
- **The exhaust pipe can generate condensation; in this case it is advisable to establish suitable condensate collection systems.**

 Failure to meet these requirements undermine the proper functioning of the boiler. Comply with the instructions given in the diagrams.

 The boilers work with the combustion chamber in depression, so it is necessary to have a flue pipe that extracts the flue gases properly.

**Fume duct material:** The pipes to be installed must be rigid, of stainless steel and have a minimum thickness of 0,5 mm, with joints for the union between the different sections and accessories.

**Isolation:** Smoke ducts must be double wall insulated to ensure that the fumes do not cool during the course to the exterior, which would lead to improper drainage and condensation that could damage the appliance.

**“T” output:** Always use an inspection “T” on the boiler outlet.

**Chimney crown:** you should always install a chimney crown to prevent the return of fumes.

**Depression in chimney:** Any other type of installation must ensure a depression of 18 to 21 Pa (depending on the boiler model) measured at hot and at maximum power.

## 8. Hydraulic Installation

- \* You can find in chapter 13 (installation diagrams) possible connection schemes in the context of a central heating installation, with or without domestic water heating;
- \* The minimum connection temperature of the circulation pump should be 60°C. It is advisable to install an anti-condensation valve to avoid condensation phenomena inside the boiler;
- \* The pump must be applied in the return circuit, where the temperature is lower;
- \* The thermostat should be diving, and just like the combustion regulator, it should be applied to the hot water outlet pipe;
- \* Solzaima advises an open pot installation, and the pipe connecting it to the boiler return should not have a diameter of less than 20 mm. No vents should be installed;
- \* If the installation option is a closed expansion vessel, this must be sized according to the installation and the safety valves must be 3 bar (suitable for use up to 90°C). It is advisable to fit a thermal discharge valve;
- \* To emptying the appliance, a tap shall be placed at one of the exits provided for that purpose in the lower area of the appliance;
- \* The heat transport fluid must be water with the addition of an anti-corrosion, non-toxic product and in the quantity recommended by the product manufacturer;
- \* The automatic combustion regulator prevents the water temperature inside the appliance from rising too high if the thermal power removed is lower than that produced. It does this by reducing the primary air intake and therefore decreasing the combustion speed. This is an important protection and safety mechanism, preventing water from boiling and/or the pressure from increasing too much, by making emergency safety devices work. The regulator must be placed on the thread indicated in the diagram and must be adjusted to close the primary air inlet door at 80°C - **to achieve proper operation of any of the equipment referred to in this manual, the automatic combustion regulator must always be installed.**
- \* If there is a risk of freezing in the space in which the recovered is located or in the fluid lines, the installer shall add antifreeze to the circulating fluid in the proportion recommended by its manufacturer to avoid freezing at the minimum absolute temperature expected.
- \* Never connect the stove without the hydraulic circuit being filled with fluid and in full operation.

\* It is essential to be able to access the various components of your hydraulic installation during the useful life of your equipment to be able to carry out regular maintenance and intervene or replace components that are necessary over time.

### **8.1 Calculation for the minimum volume of the buffer tank**

Calculation for the minimum volume of the buffer tank according to the European standard EN 303-5: 2012 apply the following formula,

$$VSP = 15 \times TB \times QN \times (1 - 0,3 \times QH/Q_{\min})$$

Where:

VSP = minimum volume buffer tank (l)

TB = combustion time (h)

QN = rated power (kW)

QH = needed for installation (kW)

$Q_{\min}$  = minimum boiler output (kW)

Example of calculation of the buffer tank:

Combustion Duration: 2 hours (the time required for combustion of the fuel charge)

Nominal boiler power: 32 kW

Minimum boiler power: 32 kW

Thermal load of the building: 25 kW

Minimum volume required =  $15 \times 2 \times 32 \times (1 - 0,3 \times 25/32) \approx 735$  l

### **8.2 Method of calculating the volume expansion vessel**

The volume of an enclosed membrane expansion vessel (diaphragm) for a heating installation is calculated using the following formula,

$$V = \frac{e \cdot C}{1 - \frac{P_1}{P_f}}$$

Where:

V = volume of the vessel (l);

$e$  = coefficient of expansion of the water. Calculated based on the difference between the maximum temperature of the water in the installation and the maximum cold working. **In practice, for heating, it assumes the conventional value of 0,035;**

$C$  = the total water content of the system (l);

$P_i$  = initial absolute pressure (bar) at an elevation that is installed on the vessel, represented by the hydrostatic pressure + 0,3 bar + atmospheric pressure (1 bar). In practice it is the preload pressure of the vessel increased from 1 bar;

$P_f$  = final absolute pressure (bar) represented by the maximum system pressure plus atmospheric pressure (1 bar). In practice it is the regulation of increased safety valve of 1 bar.

T (°C)	coef. "e"	T (°C)	coef. "e"	T (°C)	coef. "e"
0	0,00013	40	0,00782	75	0,02575
10	0,00025	45	0,00984	80	0,02898
15	0,00085	50	0,01207	85	0,03236
20	0,00180	55	0,01447	90	0,03590
25	0,00289	60	0,01704	95	0,03958
30	0,00425	65	0,01979	100	0,04342
35	0,00582	70	0,02269		

**Table 3 - Water Expansion Ratios**

Scale an expansion vessel for a heating system with the following characteristics:

$C$  = water content = 600 l

$P_{hyd}$  = hydrostatic pressure at the installation site = 1 bar

$P_{seg}$  = set pressure of the safety valve = 3 bar

**Solution:**

Applying the formula above, where:

$e = 0,035$  valor convencional

$P_i = P_{hid} + 0,3 + P_{atm} = 1 + 0,3 + 1 = 2,3$  bar

$P_f = P_{seg} + P_{atm} = 3 + 1 = 4$  bar

Therefore:  $V = (0,035 \cdot 600) \div [1 - (2,3 \div 4)] \approx 49.41$  l

We must check in a manufacturer's catalogue of expansion vessels and therefore choose a vessel with a capacity equal to or greater than the calculated value.

## 9. Fuel

*Please note: **all** regulations and standards must be met in the installation of this equipment.*

\* Only dry wood should be used in this type of equipment. It cannot be used as an incinerator and other materials such as coal, wood with paints, varnishes, thinners, liquid fuels, glues and plastics should be excluded. Also avoid burning common combustible materials like cardboard and straw.

\* Wood should have a low (less than 20%) moisture content to provide efficient combustion, avoid creosote deposition in the flue and glass and minimize oxidation of the equipment;

\* The following Table 4 (next page) with some types of wood that can be used in this equipment;

Common name	Scientific name	Distribution (Total: 18 districts)	Comments	Characteristics				
				Smoke	Heat	Firing	Speed combustion	Toughness
Pine tree	Pinus	Bragança, Castelo Branco, Coimbra, Guarda, Leiria, Viana do Castelo, Vila Real and Viseu	predominant tree	Little	Strong	Easy	Fast	Soft
Cork (+)	Quercus suber	Évora, Faro, Portalegre, Santarém and Setúbal	predominant tree	Little	Very strong	Easy	Medium	Hard
Eucalyptus	Eucalyptus	Aveiro, Porto and Lisbon	predominant tree	Much	Medium	Difficult	Slow	Hard
Holm (+)	Quercus ilex	Beja and Évora	predominant tree	Little	Very strong	Difficult	Slow	Hard
Olive tree	Olea	The entire country except alpine areas	less prevalent tree than previous	Little	Very strong	Difficult	Slow	Hard
Oak	Quercus	<i>Nationwide ranging subspecies</i>	less prevalent tree than previous	Little	Strong	Difficult	Slow	Hard
Freixo	Fraxinus	<i>river zones (Low Vouga)</i>	Distributed throughout the country in smaller numbers	Medium	Strong	Difficult	Slow	Hard
Birch / Birch	Birch	<i>Highlands (Serra da Estrela)</i>	Distributed throughout the country in smaller numbers	Little	Very strong	Easy	Fast	Soft
Beech	Fagus	<i>Regions of cold weather and high humidity (North Portugal - Serra do Gerês)</i>	Distributed throughout the country in smaller numbers	Little	Strong	Difficult	Slow	Hard
Elm	Ulmus	<i>The entire country except alpine areas (wetlands)</i>	Distributed throughout the country in smaller numbers	Medium	Strong	Difficult	Slow	Hard
Board / False - Maple	Acer	<i>Minho, Beira Litoral and Serra de Sintra</i>	Distributed throughout the country in smaller numbers	Little	Medium	Medium	Slow	Soft
Poplar	Populus	<i>Throughout the country with predominance in Center</i>	Distributed throughout the country in smaller numbers	Little	Strong	Easy	Fast	Soft
Chestnut	Castanea	<i>North and center of Portugal and saws</i>	Distributed throughout the country in smaller numbers	Medium	Strong	Difficult	Slow	Hard

(+): Greater supply by loggers

**Table 4 - List of firewood type that can be used in a SOLZAIMA equipment, their geographical distribution and Calorific Value/Reactions**

**⚠ NOTICE!**

The unit may NOT be used as an incinerator.

## 10. First Use

Before starting the appliance, you should check the following points:

- \* Ask the installer to start the equipment, having verified the operability of the installation.
- \* In the first use of the wood-fired boiler the paint is cured, which can lead to the production of additional fumes. If this is the case, you should aerate the room by opening the windows and doors.

**⚠** The combustion chamber of the boiler and the doors are built in iron painted with high temperature paint, releasing fumes in the first burns due to the cure of the paint.

Ensure that the hydraulic circuit has been correctly mounted and is connected to the water; It must be checked whether there is sufficient air circulation in the room where the installation is made, otherwise the equipment does not work properly. For this reason, you should be aware if there are other heating devices consuming air for their operation (e.g.: gas equipment, diesel oil boilers, etc.) working at the same time.

The equipment has a manual smoke register (Figure 14) and must be adjusted by the combustion phase (ignition, burning, etc...) and the chimney run.



**Figure 14 – Smoke registry**

## 11. Lighting

- \* Fully open the chimney registry;
- \* Open the lower door and the front grille;
- \* Lay a few pinecones (preferred) or fire fighters on the ash grate (Figure 15);
- \* Put small wood;
- \* The firing period is completed when the unit chassis reaches a stable temperature - the air admission setting is automatically controlled by the combustion regulator;
- \* The combustion air is retrieved from the room where the unit is installed, therefore consuming oxygen from the room. You should ensure that any ventilation grids or other fresh air intake mechanisms always remain unobstructed.



**Figure 15 – Lighting**

## 12. Maintenance and Cleaning

To access the interior of the combustion chamber it is necessary to open the lower and upper doors (Figure 16-a and Figure 16-b). The main concern with this appliance is to periodically clean the ashes that accumulate inside the unit and fume duct, they can be collected in the lower area of the boiler through a drawer (Figure 16-c and Figure 16-d).

For the fume duct it is necessary to remove the front register and the grate from the bottom of the combustion chamber, then scrape the ash from the inside with the

poker (Figure 16-e, Figure 16-f and Figure 16-g) the ash must be collected in the lower area of the boiler with the aid of the drawer.



a)



b)



c)



d)



e)



f)



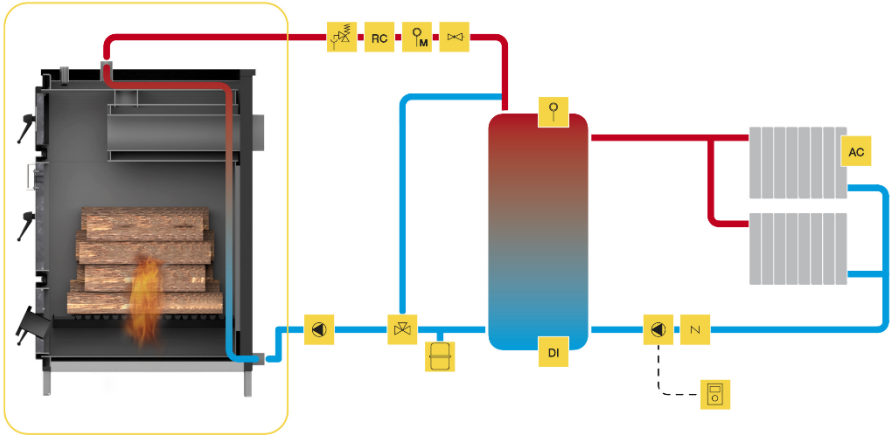
g)

**Figure 16 – Cleaning the combustion chamber**

**Note:** However, before starting to clean, you must allow the unit to cool down completely to prevent a burning accident.

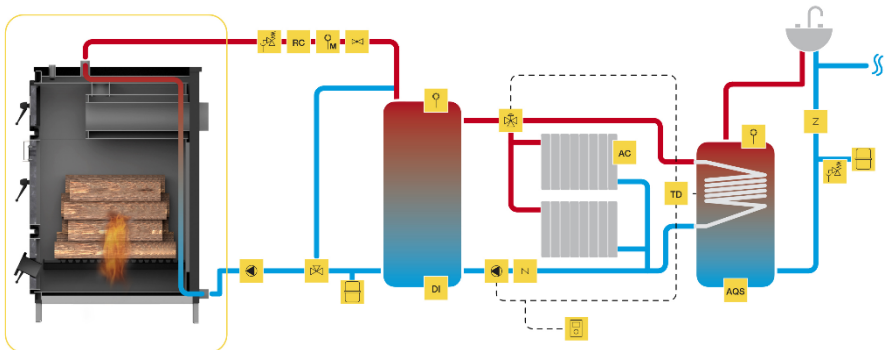
### 13. Installation Diagrams

#### Central heating installation diagram



**Figure 17 – Central heating installation diagram**

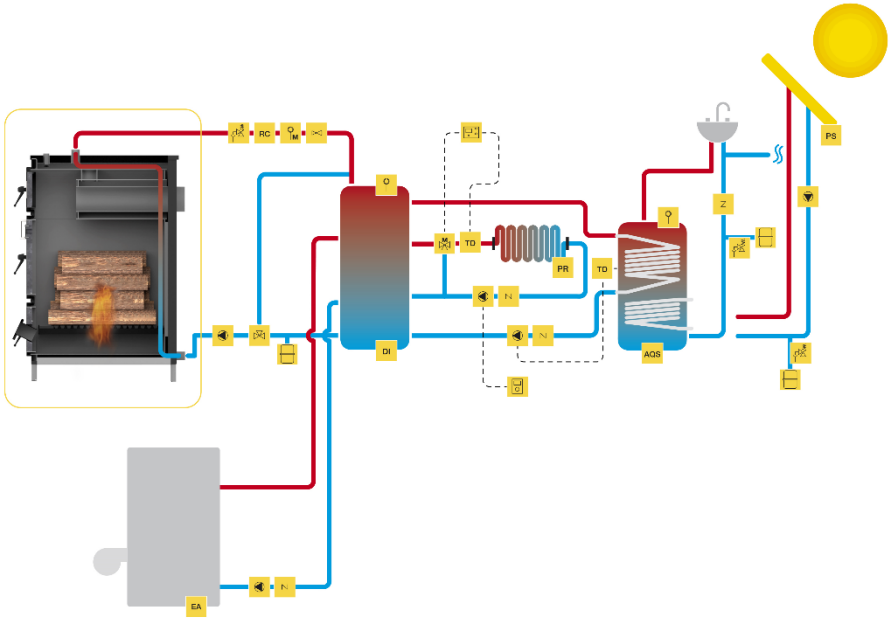
#### Central heating installation diagram and RHW



**Figure 18 – Central heating and RHW installation diagram**



## Installation diagram for central heating, RHW, radiant heated floor and solar panel with a backup pellet boiler



**Figure 20 – Installation diagram for central heating and household water heating using a hot water tank**

### Symbols

EA	Backup equipment (gas, diesel)	Z	Anti-recirculation valve		Anti-condensation valve
DI	Inertia deposit		Circulating pump		Thermal safety valve
AQS	Residential hot water		3-way motor valve		Pressure safety valve
PS	Solar panel		Automatic drain		Radiant heated floor controller
AC	Central heating		Manual drain		Room thermostat
P	Pressure sensor		Closed expansion vessel		Hot water
TD	Differential thermostat		Drain valve		Cold water
PR	Radiant heated floor		Recirculation mixer		Electrical connections

**Figure 21 – Symbols**

## 14. Life cycle of the wood fired boiler

Around 90% of the materials used to manufacture these appliances are recyclable, for a reduced environmental impact and a more sustainable planet. End-of-life units should be processed by licensed waste operators. We advise contacting your local council to ensure they are properly collected and handled.

## 15. Sustainability

Solzaima designs and manufactures biomass solutions and biomass-fuelled equipment as a primary energy source. This is our contribution for the sustainability of our planet – an economically viable and environmentally-friendly alternative, following environmental best management practices to ensure an efficient carbon cycle management.

Solzaima makes all efforts to learn and to know the national forest park while efficiently responding to energy demands, taking permanent care to maintain its biodiversity and natural wealth that are essential for the quality of life on our planet.

SOLZAIMA is a member of the Portuguese **Sociedade Ponto Verde**, which manages packaging waste from products that the company places on the market, so you can take the packaging waste from your unit, such as plastic and cardboard, to your nearest recycling point.

SOLZAIMA is a member of **Amb3E**, the entity responsible for collecting waste electrical and electronic equipment (WEEE). Thus, end-of-life units with forced ventilation systems should be transported to an appropriate WEEE-processing location. When you disassemble your equipment, you can take its electrical components to your nearest WEEE collection point.



## 16. Glossary

**Ampere (A):** SI unit of measurement of electric current

**bar:** unit of pressure equal to exactly 100,000 Pa. This pressure is very close to standard atmospheric pressure.

**cal (Calorie):** it is the amount of heat required to increase one degree centigrade the temperature of one gram of water.

**cm (centimetre):** unit of measurement.

**CO (carbon monoxide):** A lightly flammable, colourless, odourless gas that is very dangerous due to its high toxicity.

**CO<sub>2</sub> (carbon dioxide):** Gas needed by plants for photosynthesis on the one hand, and emitted into the atmosphere on the other, contributing to the greenhouse effect.

**Combustion:** a process that releases energy. Combustion is basically a chemical reaction that requires three items to take place: fuel, oxidiser and ignition temperature.

**Combustive agent:** the chemical substance that feeds combustion (essentially oxygen), that must be present for the combustion to take place.

**Combustible:** property of any material that can ignite; wood, in this example.

**Creosote:** chemical compound created by combustion. This compound is sometimes deposited on the glass and flue of an insert fire.

**Circuit breaker:** Electromechanical device that protects a given electrical appliance. Energetic efficiency: capacity to generate large quantities of heat with the least amount of energy possible, causing the least environmental impact and reducing the energy budget.

**CO emissions:** emission of carbon monoxide gas into the atmosphere.

**CO emissions (13% of O<sub>2</sub>):** monoxide content corrected to 13% of O<sub>2</sub>.

**Differential switch:** protects people and property against grounding failures, preventing electric shocks and fires.

**kcal (kilo calorie):** multiple of the unit of measurement calorie. Equivalent to 1000 calories.

**kW (kilowatt):** unit of measurement equal to 1,000 watts.

**mm (millimetre):** unit of measurement.

**mA (milliamp):** unit of measurement of electric current.

**Pa (Pascal):** standard IS unit for pressure and tension. This unit is named after Blaise Pascal, eminent French mathematician, physicist and philosopher.

**Heating capacity:** also known as specific combustion heat. It represents the amount of heat released when a certain amount of fuel is completely burned. Calorific value is expressed in calories (or kilo calories) per unit of weight of fuel.

**Rated power:** Electric power consumed from the energy source. Measured in watts.

**Rated net heating value:** heating capacity, i.e. the heat energy the unit transfers from energy present in the firewood – measured for a standard load of firewood over a given period.

**Power output:** a manufacturer's recommendation from tests on the equipment with firewood loads within a reasonable operating range. This power output range will show different firewood consumptions per hour.

**Plumb:** the vertical distance to measure the highest point of the installation.

**Output:** expressed as a percentage of “useful energy” that can be extracted from a given system, considering the “total energy” of the used fuel.

**Ignition temperature:** temperature above which the fuel can enter into combustion.

**Heat-resistant:** resistant to high temperatures and thermal shock.

**Glass ceramic:** highly resistant ceramic material produced from the controlled crystallisation of vitreous materials. Widely used in industrial applications.

**W (Watt):** the IS unit used used to measure power.

## **17. Warranty**

All SOLZAIMA boilers have a 2 (two) year warranty, starting from the invoice issue date. For your warranty to be valid, you must keep the invoice or receipt of purchase throughout the warranty period.

### **17.1. Model specific conditions**

This model requires that the unit is subject to start-up for the warranty to be to activate. The start-up service can only be performed by technical services authorised by the manufacturer. This is mandatory before the unit reaches 100 service hours. The final user is responsible for any expenses related to the start-up service.

### **17.2. Warranty General Conditions**

#### **1. Social name and address of the producer and Object**

Solzaima, S.A.

Rua dos Outarelos, 111

3750-362 Belazaima do Chão

This document does not substantiate the provision by Solzaima S.A. of a voluntary warranty on its produced and marketed products (from now on mentioned as "Product (s)"), but rather a guide, intended to be enlightening for the effective activation of the legal warranty that benefits consumers (from now on mentioned as "Warranty"). This document does not affect the legal rights of warranty, emerging from the purchase agreement whose purpose is the Product(s).

#### **2. Product identification on which rests the warranty**

The activation of the warranty presupposes prior and correct identification of the product object towards Solzaima, SA, being promoted by providing the Product ´s packing data indicated in the purchase invoice or in the product characteristics plate (model and serial number).

#### **3. Product warranty terms**

3.1 Solzaima, S.A., responds to the Buyer, for the lack of conformity of the

Product with the respective contract of sale, within the following periods:

3.1.1 A period of 24 months from the date of delivery of the good, in the case of domestic use of the product, save the provisions of the following number regarding the intensive use.

3.1.2 A term of 6 months from the date of delivery of the goods, in the case of professional, or industrial, or intensive use of the products - Solzaima means by professional, industrial or intensive use of all products installed in industrial spaces, commercial, or whose use exceeds 1500 hours per calendar year.

3.2 A functional test of the product must be performed before finishing the installation (plaster, masonry, coatings, paintings, among others).

3.3 No equipment can be replaced after the 1st Burn without the express authorization of the producer.

3.4 Any product must be repaired on the site of installation without causing serious inconvenience to the parties, save, if this proves impossible, or disproportionate.

3.5 In order to exercise its rights, and provided that the term indicated in 3.1 is not exceeded, the Buyer must report in writing to Solzaima, S.A., the lack of conformity of the Product within a maximum period of:

3.5.1 60 (sixty) days after the date on which it has detected it in the case of domestic use of the product.

3.5.2 Thirty (30) days from the date of its detection, in the case of professional use of the Product.

3.6 In the pellet range equipment's, the commissioning service is required to activate the warranty. It must be registered up to 3 months after the date of invoice, or, 100 hours of work of the product (whichever occurs first).

3.7 During the Warranty period referred to in paragraph 3.1 (and for this to remain valid), repairs to the Product must be performed exclusively by the Official Technical Services of the Brand. All services provided under this Guarantee will be performed Monday through Friday within the working time and calendar legally established in each region.

3.8 All requests for assistance must be submitted to the Solzaima, S.A. Customer support service, by means of a proper form present on the Website [www.solzaima.co.uk](http://www.solzaima.co.uk), or e-mail: [support.cliente@solzaima.pt](mailto:support.cliente@solzaima.pt). At the time of the technical assistance to the Product, the Buyer must present, as proof of the Product Warranty, the purchase invoice of the same or another document demonstrating its acquisition. In any case, the document proving the acquisition of the Product must contain the identification of the Product (as mentioned in point 2 above) and its date of acquisition. Alternatively, and to validate the Product Warranty, the PSR - document certifying the commissioning of the machine (when applicable)).

3.9 The Product will have to be installed by a qualified professional for the purpose, in accordance with the regulations in force in each geographical area, for the installation of these Products and complying with all the regulations in force, especially regarding chimneys, as well as other applicable regulations for aspects such as water supply, electricity and / or other related to the equipment or sector and as described in the instruction manual.

A product installation that does not conform to the manufacturer's specifications and / or does not comply with the legal regulations on this subject will not give rise to the application of this Warranty. Whenever a product is installed outdoors, it must be protected against weather effects such as rain and wind. In these cases, it may be necessary to protect the appliance by means of a cabinet, or a properly ventilated protective case. Appliances should not be installed in places that contain chemicals in their atmosphere, in saline or high humidity environments, as mixing them with air may produce rapid corrosion in the combustion chamber. In this type of environment, it is especially recommended that the appliance be protected with anti-corrosion products for this purpose, especially during times of operation. As a suggestion it is indicated the application of graphite greases indicated for high temperatures with function of lubrication and anti-corrosion protection.

3.10 In equipment belonging to the pellet family, in addition to the daily and weekly maintenance contained in the instruction manual, it is also obligatory to carry out the cleaning inside and in the respective chimney for the evacuation of fumes. These tasks should be carried out every 600-800 kg of pellets consumed, in the case of stoves (air and water) and compact boilers, and every 2000-3000 kg of pellets

consumed in the case of automatic boilers. If these quantities are not consumed, at least one systematic preventive maintenance must be carried out annually.

3.11 It is the Buyer's responsibility to ensure that periodic maintenance is carried out, as indicated in the instruction and handling manuals accompanying the Product. Whenever requested, it must be proved by submitting the technical report of the entity responsible for it, or alternatively by registering them in the instruction manual in the dedicated section.

3.12 In order to avoid damage to the equipment caused by overpressure, safety elements such as pressure relief valves and / or thermal discharge valves, if applicable, as well as an expansion vessel fitted to the installation, shall be ensured at the time of installation and its correct functioning must be ensured. It should be noted that: the valves referenced must have a value equal to or less than the pressure supported by the equipment; there shall be no cut-off valve between the equipment and its safety valve; provision should be made for a systematic preventive maintenance plan to attest to the correct functioning of the said safety features; irrespective of the type of appliance, all safety valves shall be channeled to drained sewage to prevent damage to the dwelling by water discharges. Product Warranty does not include damages caused by non-channeling of water discharged by said valve.

3.13 In order to avoid damage to the equipment and attached pipes by galvanic corrosion, it is advisable to use dielectric separators in the connection of the equipment to metal pipes whose characteristics of the materials applied to this type of corrosion. Product Warranty does not include damages caused by non-use of such dielectric separators.

3.14 The water or thermofluid used in the heating system (hydro stoves, boilers, central heating stoves, among others) must comply with the legal requirements in force, as well as guarantee the following physical and chemical characteristics: absence of solid particles in suspension; low level of conductivity; residual hardness of 5 to 7 degrees; neutral pH, close to 7; low concentration of chlorides and iron; and absence of air inlets by depression or others. In case the installation enhances automatic water make-up, it should consider upstream a preventive treatment system composed of filtration, decalcification and preventive dosing of

polyphosphates (scale and corrosion), as well as a degassing step, if necessary. If in any circumstance any of these indicators show values that are not recommended, the Warranty will cease to have effect. It is also compulsory to place a non-return valve between the automatic filling valve and the mains water supply, and that said supply always has constant pressure, even with a lack of electricity, not depending on lift pumps, autoclaves, or others.

3.15 Except as expressly provided by law, a warranty intervention does not renew the warranty period of the Product. The rights arising from the Warranty are not transferable to the purchaser of the Product.

3.16 The equipment must be installed in accessible places and without risk to the technician. The means necessary for access to them shall be made available by the Buyer, and the Buyer shall be responsible for any charges arising therefrom.

3.17 The Warranty is valid for the Products and equipment sold by Solzaima SA solely and exclusively within the geographical and territorial zone of the country where the Product was sold by Solzaima.

#### **4. Circumstances that exclude the application of the Warranty**

Excluded from the Warranty, being the total cost of the repair borne by the Buyer, the following cases:

4.1. Products with more than 2000 operating hours.

4.2. Refurbished and resold products.

4.3. Maintenance operations, Product settings, commissioning, cleaning, elimination of errors or anomalies that are not related to deficiencies of equipment components and replacement of the batteries

4.4. Components in direct contact with fire such as: vermiculite supports, deflector or protective plates, vermiculite, sealing lanyards, burners, ash drawers, wood chips, smoke registers, ash grates, whose wear is directly related to the conditions of use. Degradation of the paint, as well as corrosion due to degradation of the paint, due to overloading of fuel, use of an open drawer or excessive drainage of the installation chimney (the chimney must respect the drawing recommended in

the Product Technical Data Sheet). Glass breakage due to improper handling or other reason not related to Product deficiency. In the pellet family, the ignitors are aware part, so they are only guaranteed for 6 months, or 1000 ignitions (whichever comes first).

4.5. Wear considered components, such as bearings and bushes.

4.6. Deficiencies of components external to the Product that may affect its correct functioning, as well as material or other damages (e.g. tiles, roofing, waterproofing, pipes, or personal injury) caused by improper use of materials in the installation or by non-execution of the product installation in accordance with the rules for the installation, applicable regulations or rules of good art, in particular when the application of suitable piping to the temperature in use, expansion vessels, non-return valves, safety valves, anti-condensation valves, among others;

4.7. Products whose operation has been affected by failures or deficiencies of external components or by poor sizing.

4.8. Defects caused using accessories or replacement components other than those determined by Solzaima, S.A.

4.9. Defects arising from non-compliance with the installation, use and operation instructions or applications not conforming to the intended use of the Product, or from abnormal climatic factors, unusual operating conditions, overload or maintenance or cleaning performed improperly.

4.10. The Products that have been modified or manipulated by people outside the Official Technical Services of the brand and consequently without the explicit authorization of Solzaima, SA.

4.11. Damage caused by external agents (rodents, birds, spiders, etc.), atmospheric and / or geological phenomena (earthquakes, storms, frost, hailstorms, thunderstorms, etc.), humid or saline aggressive environments such as proximity of the sea or river, as well as those derived from excessive water pressure, inadequate power supply (voltage with variations greater than 10%, with a nominal value of 230V, or, neutral voltage greater than 5V, or absence of earth protection); pressure or supply of inadequate circuits, acts of vandalism, urban confrontation and armed

conflict of any kind, as well as derivatives;

4.12. Failure to use the fuel recommended by the manufacturer is a condition of exclusion from the Warranty.

Explanatory note: In the case of pellet appliances, the used fuel must be certified by EN 14961-2 grade A1. Also, before buying large quantity you should test the fuel to see how it behaves. In wood equipment, this moisture content must be of less than 20%.

4.13. The appearance of condensation, either by poor installation or using non-virgin fuels (such as pallets or wood impregnated with paints or varnishes, salt or other components), which may contribute to the accelerated degradation of equipment and especially to your combustion chamber.

4.14. All Products, Components or damaged components in transportation or installation.

4.15. Cleaning operations carried out on the appliance or its components due to condensation, fuel quality, bad settings or other circumstances of the installation location. Also excluded from the Warranty are interventions for the descalsification of the Product (the removal of limestone or other materials deposited inside the apparatus and produced by the quality of the water supply). Also excluded from this warranty are air bleeding interventions of the circuit or unblocking of circulating pumps.

4.16. The installation of the equipment supplied by Solzaima, S.A. should contemplate the possibility of their easy removal, as well as points of access to the mechanical, hydraulic and electronic components of the equipment and the installation. When the installation does not allow immediate and safe access to the equipment, the additional cost of access and security will always be borne by the Buyer. The cost of disassembling and assembling boxes of plasterboard or masonry walls, insulation or other elements such as chimneys and hydraulic connections that prevent free access to the Product (if the Product is installed inside a carton of plasterboard, masonry or other dedicated space must comply with the dimensions and characteristics indicated in the instruction manual and use accompanying the appliance).

4.17. Interventions of information or clarification at home about the use of its heating system, programming and / or reprogramming of control and regulating elements, such as thermostats, regulators, programmers, etc.

4.18. Interventions for the adjustment of fuel receipts in pellet devices, cleaning, detection of water leaks in pipes external to the apparatus, damage caused due to the need to clean the gas evacuation machinery or flues.

4.19. Urgency interventions not included in the provision of Warranty ie, weekend and holiday interventions because they are special interventions not included in the guaranteed coverage and which therefore have an additional cost, will be carried out exclusively on request expressed by the Buyer and upon the availability of the Producer.

## **5. Warranty Inclusion**

Solzaima, S.A. will correct without any charge to the Buyer the defects covered by the Warranty through the repair of the Product. The replaced Products or Components shall become the property of Solzaima, S.A.

## **6. Responsibility of Solzaima, S.A**

Notwithstanding legally established, Solzaima, S.A., liability in respect of warranty is limited to that established in the present warranty conditions.

## **7. Cost of Services performed outside the scope of the warranty**

The interventions carried out outside the scope of the warranty are subject to the application of the current tariff.

## **8. Warranty Services performed out of scope Warranty**

The interventions carried out outside the scope of the Warranty and carried out by the official technical assistance service of Solzaima have a 6-month guarantee.

## **9. Warranty Spare Parts provided by Solzaima**

Parts supplied by Solzaima as part of the commercial sale of spare parts, i.e. those not incorporated into the equipment, are not guaranteed.

## **10. Replaced Parts under the of Scope Technical Service**

From the moment they are removed from the equipment, the Parts used are considered as waste. Solzaima as a producer of waste in the scope of its activity is obliged by the legislation in force to deliver them to a licensed entity that performs the proper waste management operations under the law and therefore is prevented from giving them another destination, whatever. Therefore, the customer will be able to see the used parts resulting from the assistance but cannot keep them in their possession.

#### **11. Administrative expenses**

In the case of invoices for services rendered, they are not processed in any stipulated period with default interest at the maximum legal rate in force.

#### **12. Competent court**

For the resolution of any dispute arising from the purchase and sale agreement having as object the products covered by the warranty, the contracting parties attribute exclusive jurisdiction to the courts of the district of Águeda, with express waiver of any other.

## 18. Statement of Performance

**DECLARAÇÃO DE DESEMPENHO | DECLARACIÓN PRESTACIONES | DECLARATION OF PERFORMANCE |  
DÉCLARATION DE PERFORMANCE | DICHIARAZIONE DELLE PRESTAZIONI**

Nº DD-047

1. Código de identificação único do produto-tipo | Código de identificación único del tipo de producto | Unique identification code of the product type | Le code d'identification unique du type de produit | Codice unico di identificazione del tipo di prodotto

CALDEIRA SZM W PLUS 25 kW – EAN 05600990454767

2. Número do tipo, lote ou série do produto | Número de tipo, lote o serie del producto | Number of type, batch or serial product | Nombre de type, de lot ou de série du produit | Numero di tipo, di lotto, di serie del prodotto

3. Utilização prevista | Uso previsto | Intended use | Utilisation prevue | Destinazione d'uso

AQUECIMENTO DE EDIFÍCIOS DE HABITAÇÃO | CALEFACCIÓN DE EDIFICIOS RESIDENCIALES | HEATING OF RESIDENTIAL BUILDINGS | CHAUFFAGE DE BATIMENTS RESIDENTIELS | RISCALDAMENTO DEGLI EDIFICI RESIDENZIALI

4. Nome, designação comercial registada e endereço de contacto do fabricante | Nombre, marca registrada y la dirección de contacto de lo fabricante | Name, registered trade name and contact address of the manufacturer | Nom, marque déposée et l'adresse de contact du fabricant | Nome, denominazione commerciale registrata e Indirizzo del costruttore

SOLZAIMA, SA  
RUA DA COVA DA AREIA (E.M. 605), 695  
3750-071 AGUADA DE CIMA – ÁGUEDA – PORTUGAL

5. Sistema de avaliação e verificação da regularidade do desempenho do produto | Sistema de evaluación y verificación de constancia de las prestaciones del producto | System of assessment and verification of constancy of the product | Système d'évaluation et de vérification de la Constance des performances du produit | Sistema di valutazione e verifica della costanza della prestazione del prodotto

SISTEMA 3

6. Norma Harmonizada | Estandár armonizado | Harmonized standard | Norme harmoisée | Standard armonizzata

EN 303-5:2012

7. Nome e número de identificação do organismo notificado | Nombre y número de identificación del organismo notificado | Name and identification number of the notified body | Nom et numéro d'identification de l'organisme notifié | Nome e numero di identificazione dell'organismo notificato

TERMOPLAM Ltd  
Sofia, jk. Razsadnik-Konjovica, bl.82, vh.B, et.3, ap.53

## 8. Relatório de ensaio | Informe de la prueba | Test report | Rapport d'essai | Rapporto di prova

Nº112

## 9. Desempenho declarado | Desempeño declarado | Declared performance | Performance déclarée | Dichiarazione di prestazione

Características essenciais   Características esenciales   Essencial characteristics   Caractéristiques essentielles   Caratteristiche essenziali	Desempenho   Desempeño   Performance   Prestazione	Especificações técnicas harmonizadas   Especificaciones técnicas armonizadas   Harmonized technical specifications   Spécifications techniques harmonisées   Specifiche tecniche armonizzate
	Maximum load	Maximum load
Potência nominal entrada   Potencia de entrada nominal   Nominal heat input   Puissance d'entrée nominale   Potenza d'ingresso nominale	<b>27,5 kW</b>	---
Potência nominal saída   Potencia de salida nominal   Nominal heat output   Puissance de sortie nominale   Potenza nominale	<b>25 kW</b>	---
Eficiência das caldeiras (método directo)   Rendimiento de la caldera (método directo)   Boiler efficiency (direct method)   L'efficacité de la chaudière (méthode directe)   Efficiencia della caldaia (metodo diretto)  Classe eficiência   Clase de eficiencia   Efficiency class   Classe d'efficacité   Classe di efficienza	<b>89,8 %</b>  <b>Class 5</b>	<b>class 5</b> $\eta_K \geq 87 + \log Q$ <b>class 4</b> $\eta_K \geq 80 + 2 \times \log Q$ <b>class 3</b> $\eta_K \geq 67 + 6 \times \log Q$  According EN 303-5
Temperatura gases combustão   Temperatura de humos   Flue gas temperature   Température de gaz de combustion   Temperatura fumi	<b>193 °C</b>	---
Temperatura ambiente   Temperatura de la habitación   Room temperature   La température ambiente   Temperatura ambiente	<b>25 °C</b>	15 - 30 °C
O <sub>2</sub> - concentração   O <sub>2</sub> - concentración   O <sub>2</sub> - concentration   O <sub>2</sub> - concentration   O <sub>2</sub> - concentrazione	<b>7,2 % vol</b>	---

CO – emissão (10% O <sub>2</sub> )   CO emisión (10% O <sub>2</sub> )   CO – emission (10% O <sub>2</sub> )   CO émission (10% O <sub>2</sub> )   CO emissione (10% O <sub>2</sub> )  Classe de emissão   Clase de emisiones   Emission class   Émission   Classe di emissione	<b>539,4 mg/m<sup>3</sup></b>  <b>Class 5</b>	≤ 700 mg/m <sup>3</sup>  According EN 303-5
OGC – emissão (CxHy) (10% O <sub>2</sub> )   OGC emisión (CxHy) (10% O <sub>2</sub> )   OGC – emission (CxHy) (10% O <sub>2</sub> )   OGC émission (CxHy) (10% O <sub>2</sub> )   CO emissione (CxHy) (10% O <sub>2</sub> )  Classe de emissão   Clase de emisiones   Emission class   Émission   Classe di emissione	<b>24,4 mg/m<sup>3</sup></b>  <b>Class 5</b>	≤ 30 mg/m <sup>3</sup>  According EN 303-5
Emissão poeira (10% O <sub>2</sub> )   Emisión de polvo (10% O <sub>2</sub> )   Dust-emission (10% O <sub>2</sub> )   Émissions de poussières (10% O <sub>2</sub> )   Emissione di polveri (10% O <sub>2</sub> )  Classe de emissão   Clase de emisiones   Emission class   Émission   Classe di emissione	<b>37,8 mg/m<sup>3</sup></b>  <b>Class 5</b>	≤ 60 mg/m <sup>3</sup>  According EN 303-5

10. O desempenho do produto declarado nos pontos 1 e 2 é conforme com o desempenho declarado no ponto 9. A presente declaração de desempenho é emitida sob exclusiva responsabilidade do fabricante identificado no ponto 4. | El funcionamiento del producto se indica en los puntos 1 y 2 es compatible con las prestaciones declaradas en el punto 9. La presente declaración se expide bajo la exclusiva responsabilidad del fabricante identificado en lo punto 4. | Performance of the product stated in points 1 and 2 is consistent with the declared performance in point 9. This declaration of performance is issued under the sole responsibility of the manufacturer identified in point 4. | Les performances du produit indiqué dans les points 1 et 2 est compatible avec les performances declares au point 9. Cette declaration de performance est établie sous la seule responsabilité du fabricant identifié dans le point 4. | Le prestazioni dei prodotti indicati ai punti 1 e 2 è conforme alla prestazione dichiarata al punto 9. Questa dichiarazione di prestazione è rilasciata sotto l'esclusiva responsabilità del fabbricante di cui al punto 4

Nome e cargo | Nombre y cargo | Name and title | Nom et titre | Nome e titolo  
Aguada de Cima, 12/11/2018

Nuno Sequeira (Director Geral) CEO

**DECLARAÇÃO DE DESEMPENHO | DECLARACIÓN PRESTACIONES | DECLARATION OF PERFORMANCE |  
DÉCLARATION DE PERFORMANCE | DICHIARAZIONE DELLE PRESTAZIONI**

*Nº DD-048*

1. Código de identificação único do produto-tipo | Código de identificación único del tipo de producto | Unique identification code of the product type | Le code d'identification unique du type de produit | Codice unico di identificazione del tipo di prodotto

*CALDEIRA SZM W PLUS 30 kW – FAN 05600990454774*

2. Número do tipo, lote ou série do produto | Número de tipo, lote o serie del producto | Number of type, batch or serial product | Nombre de type, de lot ou de série du produit | Numero di tipo, di lotto, di serie del prodotto

3. Utilização prevista | Uso previsto | Intended use | Utilisation prevue | Destinazione d'uso

*AQUECIMENTO DE EDIFÍCIOS DE HABITAÇÃO | CALEFACCIÓN DE EDIFICIOS RESIDENCIALES | HEATING OF RESIDENTIAL BUILDINGS | CHAUFFAGE DE BATIMENTS RESIDENTIELS | RISCALDAMENTO DEGLI EDIFICI RESIDENZIALI*

4. Nome, designação comercial registada e endereço de contacto do fabricante | Nombre, marca registrada y la dirección de contacto de lo fabricante | Name, registered trade name and contact address of the manufacturer | Nom, marque déposée et l'adresse de contact du fabricant | Nome, denominazione commerciale registrata e Indirizzo del costruttore

*SOLZAIMA, SA  
RUA DA COVA DA AREJA (E.M. 605), 695  
3750-071 AGUADA DE CIMA – ÁGUEDA – PORTUGAL*

5. Sistema de avaliação e verificação da regularidade do desempenho do produto | Sistema de evaluación y verificación de constancia de las prestaciones del producto | System of assessment and verification of constancy of the product | Système d'évaluation et de vérification de la Constance des performances du produit | Sistema di valutazione e verifica della costanza della prestazione del prodotto

*SISTEMA 3*

6. Norma Harmonizada | Estandár armonizado | Harmonized standard | Norme harmoisée | Standard armonizzata

*EN 303-5:2012*

7. Nome e número de identificação do organismo notificado | Nombre y número de identificación del organismo notificado | Name and identification number of the notified body | Nom et numéro d'identification de l'organisme notifié | Nome e numero di identificazione dell'organismo notificato

*TERMOPLAM Ltd  
Sofia, jk. Razsadnik-Konjovica, bl.82, vh.B, et.3, ap.53  
NB:2608*

8. Relatório de ensaio | Informe de la prueba | Test report | Rapport d'essai | Rapporto di prova

Nº112

9. Desempenho declarado | Desempeño declarado | Declared performance | Performance déclarée | Dichiarazione di prestazione

<b>Características essenciais    Características esenciales    Essencial characteristics    Caractéristiques essentielles    Caratteristiche essenziali</b>	<b>Desempenho    Desempeño    Performance    Prestazione</b>	<b>Especificações técnicas  harmonizadas    Especificaciones técnicas  armonizadas  Harmonized  technical specifications    Spécifications techniques  harmonisées   Specifiche  tecniche armonizzate</b>
	<b>Maximum load</b>	<b>Maximum load</b>
Potência nominal entrada   Potencia de entrada nominal   Nominal heat input   Puissance d'entrée nominal   Potenza d'ingresso nominale	<b>36 kW</b>	---
Potência nominal saída   Potencia de salida nominal   Nominal heat output   Puissance de sortie nominale   Potenza nominale	<b>30 kW</b>	---
Eficiência das caldeiras (método directo)   Rendimiento de la caldera (método directo)   Boiler efficiency (direct method)   L'efficacité de la chaudière (méthode directe)   Efficienza della caldaia (metodo diretto)  Classe eficiência   Clase de eficiência   Efficiency class   Classe d'efficacité   Classe di efficienza	<b>90,2 %</b>   <b>Class 5</b>	<b>class 5</b> $\eta_K \geq 87 + \log Q$ <b>class 4</b> $\eta_K \geq 80 + 2 \times \log Q$ <b>class 3</b> $\eta_K \geq 67 + 6 \times \log Q$  According EN 303-5
Temperatura gases combustão   Temperatura de humos   Flue gas temperature   température de gaz de combustion   Temperatura fumi	<b>191,5°C</b>	---
Temperature ambiente   Temperatura de la habitación   Room temperature   La température ambiante   Temperatura ambiente	<b>25 °C</b>	15 - 30 °C
O <sub>2</sub> - concentração   O <sub>2</sub> - concentración   O <sub>2</sub> - concentration   O <sub>2</sub> - concentration   O <sub>2</sub> - concentrazione	<b>6,95 % vol</b>	---
CO - emissão (10% O <sub>2</sub> )   CO emisión (10% O <sub>2</sub> )   CO - emission (10% O <sub>2</sub> )   CO émission (10% O <sub>2</sub> )   CO emissione (10% O <sub>2</sub> )  Classe de emissão   Clase de emisiones   Emission class   Émission   Classe di emissione	<b>548,5 mg/m<sup>3</sup></b>   <b>Class 5</b>	$\leq 700 \text{ mg/m}^3$   According EN 303-5

<p>OGC – emissão (CxHy) (10% O<sub>2</sub>)   OGC emisión (CxHy) (10% O<sub>2</sub>)   OGC – emission (CxHy) (10% O<sub>2</sub>)   OGC émission (CxHy) (10% O<sub>2</sub>)   CO emisione (CxHy) (10% O<sub>2</sub>)</p> <p>Classe de emissão   Clase de emisiones   Emission class   Émission   Classe di emissione</p>	<p><b>26,2 mg/m<sup>3</sup></b></p> <p><b>Class 5</b></p>	<p>≤ 30 mg/m<sup>3</sup></p> <p>According EN 303-5</p>
<p>Emissão poeira (10% O<sub>2</sub>)   Emisión de polvo (10% O<sub>2</sub>)   Dust-emission (10% O<sub>2</sub>)   Émissions de poussières (10% O<sub>2</sub>)   Emissione di poleveri (10% O<sub>2</sub>)</p> <p>Classe de emissão   Clase de emisiones   Emission class   Émission   Classe di emissione</p>	<p><b>39,2 mg/m<sup>3</sup></b></p> <p><b>Class 5</b></p>	<p>≤ 60 mg/m<sup>3</sup></p> <p>According EN 303-5</p>

10. O desempenho do produto declarado nos pontos 1 e 2 é conforme com o desempenho declarado no ponto 9. A presente declaração de desempenho é emitida sob exclusiva responsabilidade do fabricante identificado no ponto 4. | El funcionamiento del producto se indica en los puntos 1 y 2 es compatible con las prestaciones declaradas en el punto 9. La presente declaración se expide bajo la exclusiva responsabilidad del fabricante identificado en lo punto 4. | Performance of the product stated in points 1 and 2 is consistent with the declared performance in point 9. This declaration of performance is issued under the sole responsibility of the manufacturer identified in point 4. | Les performances du produit indiqué dans les points 1 et 2 est compatible avec les performances declares au point 9. Cette declaration de performance est établie sous la seule responsabilité du fabricant identifié dans le point 4. | Le prestazioni dei prodotti indicati ai punti 1 e 2 è conforme alla prestazione dichiarata al punto 9. Questa dichiarazione di prestazione è rilasciata sotto l'esclusiva responsabilità del fabbricante di cui al punto 4

Nome e cargo | Nombre y cargo | Name and title | Nom et titre | Nome e titolo  
Aguada de Cima, 12/11/2018

Nuno Sequeira (Director Geral) CEO

**DECLARAÇÃO DE DESEMPENHO | DECLARACIÓN PRESTACIONES | DECLARATION OF PERFORMANCE |  
DÉCLARATION DE PERFORMANCE | DICHIARAZIONE DELLE PRESTAZIONI**

Nº DD-049

1. Código de identificação único do produto-tipo | Código de identificación único del tipo de producto | Unique identification code of the product type | Le code d'identification unique du type de produit | Codice unico di identificazione del tipo di prodotto

CALDEIRA SZM W PLUS 35 kW – FAN 05600990454781

2. Número do tipo, lote ou série do produto | Número de tipo, lote o serie del producto | Number of type, batch or serial product | Nombre de type, de lot ou de série du produit | Numero di tipo, di lotto, di serie del prodotto

3. Utilização prevista | Uso previsto | Intended use | Utilisation prévue | Destinazione d'uso

AQUECIMENTO DE EDIFÍCIOS DE HABITAÇÃO | CALEFACCIÓN DE EDIFICIOS RESIDENCIALES | HEATING OF RESIDENTIAL BUILDINGS | CHAUFFAGE DE BATIMENTS RESIDENTIELS | RISCALDAMENTO DEGLI EDIFICI RESIDENZIALI

4. Nome, designação comercial registada e endereço de contacto do fabricante | Nombre, marca registrada y la dirección de contacto de lo fabricante | Name, registered trade name and contact address of the manufacturer | Nom, marque déposée et l'adresse de contact du fabricant | Nome, denominazione commerciale registrata e Indirizzo del costruttore

SOLZAIMA, SA  
RUA DA COVA DA AREIA (E.M. 605), 695  
3750-071 AGUADA DE CIMA – ÁGUEDA – PORTUGAL

5. Sistema de avaliação e verificação da regularidade do desempenho do produto | Sistema de evaluación y verificación de constancia de las prestaciones del producto | System of assessment and verification of constancy of the product | Système d'évaluation et de vérification de la Constance des performances du produit | Sistema di valutazione e verifica della costanza della prestazione del prodotto

SISTEMA 3

6. Norma Harmonizada | Estandár armonizado | Harmonized standard | Norme harmonisée | Standard armonizzata

EN 303-5:2012

7. Nome e número de identificação do organismo notificado | Nombre y número de identificación del organismo notificado | Name and identification number of the notified body | Nom et numéro d'identification de l'organisme notifié | Nome e numero di identificazione dell'organismo notificato

TERMOPLAM Ltd  
Sofia, jk. Razsadnik-Konjovica, bl.82, vh.B, et.3, ap.53  
NB:2608

8. Relatório de ensaio | Informe de la prueba | Test report | Rapport d'essai | Rapporto di prova

Nº112

9. Desempenho declarado | Desempeño declarado | Declared performance | Performance déclarée | Dichiarazione di prestazione

<b>Características essenciais  </b> <b>Características esenciales  </b> <b>Essencial characteristics  </b> <b>Caractéristiques essentielles</b> <b>  Caratteristiche essenziali</b>	<b>Desempenho  </b> <b>Desempeño  </b> <b>Performance  </b> <b>Prestazione</b>	<b>Especificações técnicas</b> <b>harmonizadas   Especificaciones</b> <b>técnicas armonizadas  </b> <b>Harmonized technical</b> <b>specifications   Spécifications</b> <b>techniques harmonisées  </b> <b>Specifiche tecniche armonizzate</b>
	<b>Maximum load</b>	<b>Maximum load</b>
Potência nominal entrada   Potencia de entrada nominal   Nominal heat input   Puissance d'entrée nominal   Potenza d'ingresso nominale	<b>38,5 kW</b>	---
Potência nominal saída   Potencia de salida nominal   Nominal heat output   Puissance de sortie nominale   Potenza nominale	<b>35 kW</b>	---
Eficiência das caldeiras (método directo)   Rendimiento de la caldera (método directo)   Boiler efficiency (direct method)   L'efficacité de la chaudière (méthode directe)   Efficienza della caldaia (metodo diretto)  Classe eficiência   Clase de eficiencia   Efficiency class   Classe d'efficacité   Classe di efficienza	<b>90,6 %</b>   <b>Class 5</b>	<b>class 5</b> $\eta_K \geq 87 + \log Q$ <b>class 4</b> $\eta_K \geq 80 + 2 \times \log Q$ <b>class 3</b> $\eta_K \geq 67 + 6 \times \log Q$  According EN 303-5
Temperatura gases combustão   Temperatura de humos   Flue gas temperature   Température de gaz de combustion   Temperatura fumi	<b>190 °C</b>	---
Temperatura ambiente   Temperatura de la habitación   Room temperature   La température ambiante   Temperatura ambiente	<b>25 °C</b>	15 - 30 °C
O <sub>2</sub> - concentração   O <sub>2</sub> - concentración   O <sub>2</sub> - concentration   O <sub>2</sub> - concentration   O <sub>2</sub> - concentrazione	<b>6,7 % vol</b>	---
CO - emissão (10% O <sub>2</sub> )   CO emisión (10% O <sub>2</sub> )   CO - emission (10% O <sub>2</sub> )   CO émission (10% O <sub>2</sub> )   CO emissione (10% O <sub>2</sub> )  Classe de emissão   Clase de emisiones   Emission class   Émission   Classe di emissione	<b>557,5 mg/m<sup>3</sup></b>   <b>Class 5</b>	$\leq 700 \text{ mg/m}^3$   According EN 303-5

<p>OGC - emissão (CxHy) (10% O<sub>2</sub>)   OGC emisión (CxHy) (10% O<sub>2</sub>)   OGC - emission (CxHy) (10% O<sub>2</sub>)   OGC émission (CxHy) (10% O<sub>2</sub>)   CO emisione (CxHy) (10% O<sub>2</sub>)</p> <p>Classe de emissão   Clase de emisiones   Emission class   Émission   Classe di emissione</p>	<p><b>27,9 mg/m<sup>3</sup></b></p> <p><b>Class 5</b></p>	<p>≤ 30 mg/m<sup>3</sup></p> <p>According EN 303-5</p>
<p>Emissão poeira (10% O<sub>2</sub>)   Emisión de polvo (10% O<sub>2</sub>)   Dust-emission (10% O<sub>2</sub>)   Émissions de poussières (10% O<sub>2</sub>)   Emissione di poleveri (10% O<sub>2</sub>)</p> <p>Classe de emissão   Clase de emisiones   Emission class   Émission   Classe di emissione</p>	<p><b>40,5 mg/m<sup>3</sup></b></p> <p><b>Class 5</b></p>	<p>≤ 60 mg/m<sup>3</sup></p> <p>According EN 303-5</p>

10. O desempenho do produto declarado nos pontos 1 e 2 é conforme com o desempenho declarado no ponto 9. A presente declaração de desempenho é emitida sob exclusiva responsabilidade do fabricante identificado no ponto 4. | El funcionamiento del producto se indica en los puntos 1 y 2 es compatible con las prestaciones declaradas en el punto 9. La presente declaración se expide bajo la exclusiva responsabilidad del fabricante identificado en lo punto 4. | Performance of the product stated in points 1 and 2 is consistent with the declared performance in point 9. This declaration of performance is issued under the sole responsibility of the manufacturer identified in point 4. | Les performances du produit indiqué dans les points 1 et 2 est compatible avec les performances declares au point 9. Cette declaration de performance est établie sous la seule responsabilité du fabricant identifié dans le point 4. | Le prestazioni dei prodotti indicati ai punti 1 e 2 è conforme alla prestazione dichiarata al punto 9. Questa dichiarazione di prestazione è rilasciata sotto l'esclusiva responsabilità del fabbricante di cui al punto 4

Nome e cargo | Nombre y cargo | Name and title | Nom et titre | Nome e titolo  
Aguada de Cima, 12/11/2018

Nuno Sequeira (Director Geral) CEO

**DECLARAÇÃO DE DESEMPENHO | DECLARACIÓN PRESTACIONES | DECLARATION OF PERFORMANCE |  
DÉCLARATION DE PERFORMANCE | DICHIARAZIONE DELLE PRESTAZIONI**

Nº DD-050

1. Código de identificação único do produto-tipo | Código de identificación único del tipo de producto | Unique identification code of the product type | Le code d'identification unique du type de produit | Codice unico di identificazione del tipo di prodotto

CALDEIRA SZM W PLUS 40 kW – FAN 05600990454798

2. Número do tipo, lote ou série do produto | Número de tipo, lote o serie del producto | Number of type, batch or serial product | Nombre de type, de lot ou de série du produit | Numero di tipo, di lotto, di serie del prodotto

3. Utilização prevista | Uso previsto | Intended use | Utilisation prévue | Destinazione d'uso

AQUECIMENTO DE EDIFÍCIOS DE HABITAÇÃO | CALEFACCIÓN DE EDIFICIOS RESIDENCIALES | HEATING OF RESIDENTIAL BUILDINGS | CHAUFFAGE DE BATIMENTS RESIDENTIELS | RISCALDAMENTO DEGLI EDIFICI RESIDENZIALI

4. Nome, designação comercial registada e endereço de contacto do fabricante | Nombre, marca registrada y la dirección de contacto de lo fabricante | Name, registered trade name and contact address of the manufacturer | Nom, marque déposée et l'adresse de contact du fabricant | Nome, denominazione commerciale registrata e Indirizzo del costruttore

SOLZAIMA, SA  
RUA DA COVA DA AREIA (E.M. 605), 695  
3750-071 AGUADA DE CIMA – ÁGUEDA – PORTUGAL

5. Sistema de avaliação e verificação da regularidade do desempenho do produto | Sistema de evaluación y verificación de constancia de las prestaciones del producto | System of assessment and verification of constancy of the product | Système d'évaluation et de vérification de la Constance des performances du produit | Sistema di valutazione e verifica della costanza della prestazione del prodotto

SISTEMA 3

6. Norma Harmonizada | Estandár armonizado | Harmonized standard | Norme harmonisée | Standard armonizzata

EN 303-5:2012

7. Nome e número de identificação do organismo notificado | Nombre y número de identificación del organismo notificado | Name and identification number of the notified body | Nom et numéro d'identification de l'organisme notifié | Nome e numero di identificazione dell'organismo notificato

TERMOPLAM Ltd  
Sofia, jk. Razsadnik-Konjovica, bl.82, vh.B, et.3, ap.53  
NB:2608

8. Relatório de ensaio | Informe de la prueba | Test report | Rapport d'essai | Rapporto di prova

Nº112

9. Desempenho declarado | Desempeño declarado | Declared performance | Performance déclarée | Dichiarazione di prestazione

<b>Características essenciais              Características esenciales              Essencial characteristics              Caractéristiques            essentielles              Caratteristiche essenziali</b>	<b>Desempenho              Desempeño              Performance              Prestazione</b>	<b>Especificações técnicas            harmonizadas   Especificaciones            técnicas armonizadas              Harmonized technical            specifications   Spécifications            techniques harmonisées              Specifiche tecniche armonizzate</b>
	<b>Maximum load</b>	<b>Maximum load</b>
Potência nominal entrada   Potencia de entrada nominal   Nominal heat input   Puissance d'entrée nominal   Potenza d'ingresso nominale	<b>44 kW</b>	---
Potência nominal saída   Potencia de salida nominal   Nominal heat output   Puissance de sortie nominale   Potenza nominale	<b>40 kW</b>	---
Eficiência das caldeiras (método directo)   Rendimiento de la caldera (método directo)   Boiler efficiency (direct method)   L'efficacité de la chaudière (méthode directe)   Efficienza della caldaia (metodo diretto)  Classe eficiência   Clase de eficiencia   Efficiency class   Classe d'efficacité   Classe di efficienza	<b>90,7 %</b>   <b>Class 5</b>	<b>class 5</b> $\eta_K \geq 87 + \log Q$ <b>class 4</b> $\eta_K \geq 80 + 2 \times \log Q$ <b>class 3</b> $\eta_K \geq 67 + 6 \times \log Q$  According EN 303-5
Temperatura gases combustão   Temperatura de humos   Flue gas temperature   température de gaz de combustion   Temperatura fumi	<b>195,7°C</b>	---
Temperatura ambiente   Temperatura de la habitación   Room temperature   La température ambiante   Temperatura ambiente	<b>25 °C</b>	15 - 30 °C
O <sub>2</sub> - concentração   O <sub>2</sub> - concentración   O <sub>2</sub> - concentration   O <sub>2</sub> - concentration   O <sub>2</sub> - concentrazione	<b>6,76 % vol</b>	---
CO - emissão (10% O <sub>2</sub> )   CO emisión (10% O <sub>2</sub> )   CO - emission (10% O <sub>2</sub> )   CO émission (10% O <sub>2</sub> )   CO emissioni (10% O <sub>2</sub> )  Classe de emissão   Clase de emisiones   Emission class   Émission   Classe di emissione	<b>559,6 mg/m<sup>3</sup></b>   <b>Class 5</b>	$\leq 700 \text{ mg/m}^3$   According EN 303-5

<p>OGC – emissão (CxHy) (10% O<sub>2</sub>)   OGC emisión (CxHy) (10% O<sub>2</sub>)   OGC - emission (CxHy) (10% O<sub>2</sub>)   OGC émission (CxHy) (10% O<sub>2</sub>)   CO emissione (CxHy) (10% O<sub>2</sub>)</p> <p>Classe de emissão   Clase de emisiones   Emission class   Émission   Classe di emissione</p>	<p><b>28 mg/m<sup>3</sup></b></p> <p><b>Class 5</b></p>	<p>≤ 30 mg/m<sup>3</sup></p> <p>According EN 303-5</p>
<p>Emissão poeira (10% O<sub>2</sub>)   Emisión de polvo (10% O<sub>2</sub>)   Dust-emission (10% O<sub>2</sub>)   Émissions de poussières (10% O<sub>2</sub>)   Emissione di poleveri (10% O<sub>2</sub>)</p> <p>Classe de emissão   Clase de emisiones   Emission class   Émission   Classe di emissione</p>	<p><b>41 mg/m<sup>3</sup></b></p> <p><b>Class 5</b></p>	<p>≤ 60 mg/m<sup>3</sup></p> <p>According EN 303-5</p>

10. O desempenho do produto declarado nos pontos 1 e 2 é conforme com o desempenho declarado no ponto 9. A presente declaração de desempenho é emitida sob exclusiva responsabilidade do fabricante identificado no ponto 4. | El funcionamiento del producto se indica en los puntos 1 y 2 es compatible con las prestaciones declaradas en el punto 9. La presente declaración se expide bajo la exclusiva responsabilidad del fabricante identificado en lo punto 4. | Performance of the product stated in points 1 and 2 is consistent with the declared performance in point 9. This declaration of performance is issued under the sole responsibility of the manufacturer identified in point 4. | Les performances du produit indiqué dans les points 1 et 2 est compatible avec les performances declares au point 9. Cette declaration de performance est établie sous la seule responsabilité du fabricant identifié dans le point 4. | Le prestazioni dei prodotti indicati ai punti 1 e 2 è conforme alla prestazione dichiarata al punto 9. Questa dichiarazione di prestazione è rilasciata sotto l'esclusiva responsabilità del fabbricante di cui al punto 4

Nome e cargo | Nombre y cargo | Name and title | Nom et titre | Nome e titolo  
Aguada de Cima, 12/11/2018

Nuno Sequeira (Director Geral) CEO